

MATERIAL SUPPORTING THE AGENDA

Volume XIXa

September 1971 - December 1971

This volume contains the Material Supporting the Agenda furnished to each member of the Board of Regents prior to the meetings held on September 8, October 22, and December 2-3, 1971.

The material is divided according to the Standing Committees and the meetings that were held and is submitted on three different colors, namely:

- (1) white paper - for the documentation of all items that were presented before the deadline date
- (2) blue paper - all items submitted to the Executive Session of the Committee of the Whole and distributed only to the Regents, Chancellor, and Chancellor Emeritus
- (3) yellow paper - emergency items distributed at the meeting.

Material distributed at the meeting as additional documentation is not included in the bound volume, because sometimes there is an unusual amount and other times maybe some people get copies and some do not get copies. If the Secretary were furnished a copy, then that material goes in the appropriate subject folder.

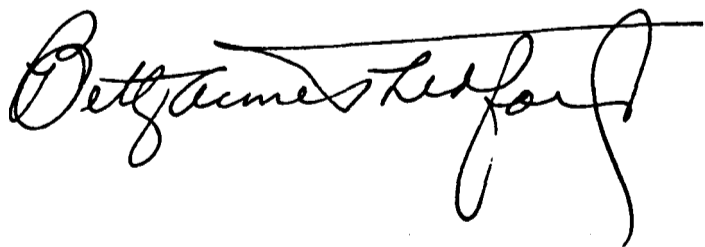
A handwritten signature in cursive script, reading "Betty James Hedford". The signature is written in black ink and is positioned in the lower right quadrant of the page.



THE BOARD OF REGENTS OF THE UNIVERSITY OF TEXAS SYSTEM

Material Supporting

# Agenda

Meeting Date: ..... December 2 -  
December 3, 1971

Meeting No.: ..... 695

Name: ..... *Official Copy*

*P. 2 + 2 - 10, Item 9 - get recommendations  
prior to meeting.*

*Docket  
CJW-12*

# Official Attendance

## Architects

Two Plans

Gail Borden

Raymond Rapp  
Ron Fash  
Eng. Ray Burns

## Arlington Fine Arts

Morris Parker  
Merv Croston  
Paul Wharton  
Ron Estill

7 lunch

One easel

Billy Carr

## STUDENTS

Courtney Roberts  
MARY HARDEE

CALENDAR  
BOARD OF REGENTS  
OF  
THE UNIVERSITY OF TEXAS SYSTEM

December 2-3, 1971

U. T. Austin  
Austin, Texas

Thursday, December 2, 1971

12:00 noon, Main Building  
Room 212

To Consider Sale of Board of  
Regents of U. T. System  
General Tuition Revenue Bonds,  
Series 1971, \$50,000,000

2:30 p. m., VIP Room  
Joe C. Thompson  
Conference Center

Presentation of academic plans,  
organizational structure and campus  
plans to Coordinating Board, Texas  
College and University System for:

U. T. Dallas  
U. T. Permian Basin  
U. T. San Antonio

Friday, December 3, 1971. --The order of the meetings is set out  
below:

9:00 a. m.

Executive Committee

Academic and Developmental Affairs  
Committee

Buildings and Grounds Committee

Medical Affairs Committee

Land and Investment Committee

Committee of the Whole

Meeting of the Board

12:00 noon - Lunch will be served in the Academic Center.

## Telephone Numbers

### Offices:

Board of Regents	471-1265
Chancellor LeMaistre	471-1434
Chancellor Emeritus Ransom	471-1741
Deputy Chancellor Walker	471-1743
President Spurr	471-1233

### Hotels:

Sheraton-Crest Inn	478-9611
Stephen F. Austin Hotel	476-4361
Villa Capri Motor Hotel	476-6171

### Airlines:

Braniff International	476-4631
Continental	477-6716
Texas International	478-9585

NOTE: Chancellor LeMaistre has asked that the institutional heads and the respective business officers sit in Section 1 and 1a so that he can easily locate them if needed at the meeting. He has also asked that those with whom he may need to confer sit in the area near his place.

DIAGRAM OF MEETING ROOM

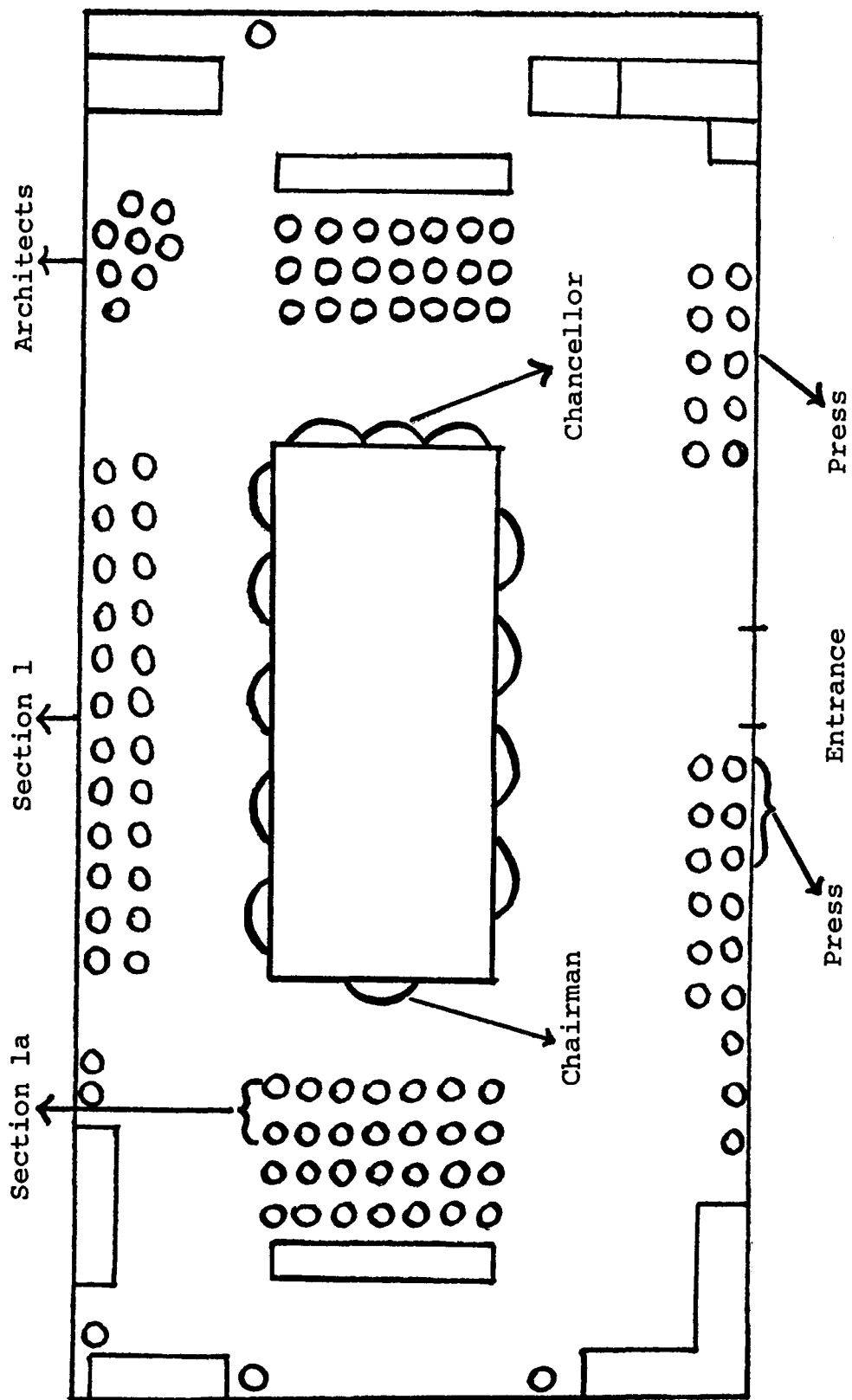

# **Executive Committee**

**EXECUTIVE COMMITTEE**

**There have been no items submitted to the Executive Committee for consideration at this meeting.**



**Academic & Developmental Affairs  
Committee**



THE UNIVERSITY OF TEXAS SYSTEM

Office of the Chancellor

601 COLORADO STREET, AUSTIN, TEXAS 78701

December 1, 1971

MEMORANDUM

TO: Regent Joe Kilgore

FROM: Charles A. LeMaistre, M.D. *CAL*  
Chancellor

SUBJECT: Response to Exceptions to Chancellor's Docket No. 52

As you have approved, I am transmitting herewith to you the System Administration response to those exceptions in the Chancellor's Docket No. 52.

I am also sending a copy of these responses to Regent Nelson via the pilots who will be picking him up in Mineral Wells.

I sincerely hope that this response will clarify and satisfy some of the exceptions which have been raised and conserve the time of the entire Board in considering these matters.

CAL:do

Attachment

cc: Regent John Peace, Chairman  
Regent Joe Nelson  
Miss Betty Anne Thedford  
Mr. E. D. Walker  
Dr. Kenneth Ashworth  
Dr. William H. Knisely

U. T. AUSTIN

I. Docket, Page M-16, Item #2 under Outside Employment, and Page M-117, Item #673 under Recommended Budget Changes

2. George L. John, M.D., Staff Physician Student Health Center, to perform routine duties of a physician at the Family Medical Center. Approximately 10-15 hours per week.

Student Health Center

Appointment

Physician, General Medicine

673. George L. John	9/1 - 8/31	100	12	\$21,000
---------------------	------------	-----	----	----------

(RBC# 534)

EXCEPTION COMMENT:

Assuming Dr. John works a 60-hour week and spends  $\frac{1}{4}$  time outside University duties, how does he carry this load? Also, what is the Family Medical Center?

This shows the above-mentioned Dr. George L. John to be 100% University time. How do we resolve the conflict?

RESPONSE:

Dr. George L. John, M.D., Staff Physician at the Student Health Center, provides consultation, as time permits, to two general practitioners, whose offices are in a building called the Family Medical Center. He moved to Austin from Nebraska to join the staff of the Student Health Center. At the time of his move, the Family Medical Center was seeking another doctor, and since one of the two doctors was a medical school classmate, Dr. John has helped out when requested, as time was available. It is his intention to remain as a full-time employee of the Student Health Center and continue only in a consultation capacity with the Family Medical Center. For these services, it is anticipated that his income will be approximately \$500 per month.

II. Docket, Page M-19, Item #24 under Outside Employment

24. Elmer L. Hixson, Professor of Electrical Engineering, to act as consultant on instrumentation, measurement and analysis of acoustical and mechanical noise and vibration, for Menasco Manufacturing Company, Fort Worth, Texas; IBM Office Products Division, Austin, Texas; and McCandless Consultants, Inc., Austin, Texas. Approximately 5 days per week.

EXCEPTION COMMENT:

What does Professor Elmer L. Hixson do with his other two days a week, and which two days are they?

RESPONSE:

The error was pointed out in Dr. LeMaistre's memorandum to the Board of November 24, -- "days" should have read "hours".

U. T. AUSTIN

III. Docket, Page M-20, Items #39 and #41 under Outside Employment

39. Allen E. Smith, Professor of Law, to provide legal representation for various private parties whose interests are not in conflict with those of the University of Texas at Austin or the University of Texas System. Approximately 8 hours per week.

41. Mark G. Yudof, Assistant Professor of Law, to act as consultant in Rodrigues v. San Antonio, a suit challenging the Texas plan for financing public education. The complaint alleges that the ability of a school district to support public education is a function of its wealth (Assessed value of property) in violation of the equal protection clause for Arthur Gochman, San Antonio, Texas. Approximately 3 hours per week.

EXCEPTION COMMENT:

Is Allen E. Smith in private practice and, if so, is he able to limit it to eight hours per week while on University salary?

Mark G. Yudof - How much time is required for a University Professor to serve in the actual trial of a lawsuit against the citizens of San Antonio?

RESPONSE:

Further information provided in Dr. LeMaistre's memorandum of November 24.

IV. Docket, Page M-91, Item #528 under Recommended Budget Changes

School of Law - Legal Aid Clinic

Appointment

Legal Aid Associate Director

528. William T. Buckle	9/1 - 8/31	100	12	\$11,000
------------------------	------------	-----	----	----------

(RBC# 419)

EXCEPTION COMMENT:

Is this the salary provided that we approved at the last meeting and the amount of money we are going to contribute to the Legal Aid Clinic on behalf of William T. Buckle?

RESPONSE:

This action appoints Mr. Buckle to the Associate Director's position at the salary of \$11,000 as included in the U. T. Austin budget approved by the Board on July 30, 1971 (p. 438). In the next docket, the appointment of John Scanlon will be submitted as Legal Aid Director ( $\frac{1}{2}$  time) at a salary rate of \$14,000 (\$7,000 of which is derived from funds approved in the U. T. Austin budget by the Board on July 30, 1971).

U. T. EL PASO

I. Docket, Page W-3, Item #6 under Government Contracts and Grants

Grant No. 8669-E/O, dated September 28, 1971, whereby the Assistant Director for Operations, Office of Economic Opportunity, Washington, D. C. 20506, awards \$239,016 in additional funding for the continuation of the High School Equivalency Program during the period September 1, 1971 through August 31, 1972. \$3,000 in carry-over funds must be assigned to this program year for a total federal share of \$242,016.

EXCEPTION COMMENT:

Grant #8669-E0: Just what is the High School Equivalency Program?

RESPONSE:

The High School Equivalency Program is a national program of testing and tutoring (if required) to provide certification that school dropouts have completed the equivalent of a high school education. This program at U.T.E.P. has been in operation since 1967 and all costs are fully funded from federal sources. The program is supervised by the School of Education and an Advisory Council to that program. The program is not an integral part of the educational program of the university and therefore is not inconsistent with its role and scope. However, it provides a much needed service to the community.

II. Docket, Page W-3, Item #1 under Non-Government Contracts and Grants

Annual Contract, dated September 20, 1971, whereby the Administrator, GED Testing Service, One Dupont Circle, Washington, D. C. 20036, enters into an agreement with The University of Texas at El Paso for the operation of an Official GED Center for a period of one year beginning on the first day of the month after shipment of test materials.

EXCEPTION COMMENT:

What is the GED Center?

RESPONSE:

A General Education Development Center administers the national tests to determine whether a school dropout has attained the educational level equivalent to a high school graduate. Such centers are designated in geographic areas of the State by the Texas Education Agency. This contract serves as an official recognition by the American Council on Education to authorize U.T.E.P. to purchase the tests and administer them in the El Paso area.

III. Docket, Page W-3, Item #2 under Non-Government Contracts and Grants

Grant from The Spencer Foundation, John Hancock Center, 875 North Michigan Avenue, Chicago, Illinois 60611, which provides the sum of \$63,701 for the support of research on Southwest Ethnic Group Relationships. The grant is effective for the period September 1, 1971 through August 31, 1973, and the research will be under the direction of Dr. Jacob Ornstein, Professor of Modern Languages, and Dr. Z. A. Kruszewski, Associate Professor of Political Science.

EXCEPTION COMMENT:

Is the modern languages Professor the only pre-requisite to do research on Southwest Ethnic Group Relationships?

RESPONSE:

The purpose of this project on Southwest Ethnic Group Relationships is to gather, during the contract period, as much information and data as possible on the tensions, problems, and perceptions of ethnic groups such as the Indians, Syrians, Lebanese, Mexican-Americans, Germans, Swedes, etc. It is hoped that such information will help in making proper responses to minority group demands in colleges and curricula. The findings may assist in determining what responses are inappropriate, impractical or of limited meaning, as well. Many talents will be brought to bear in the research of which linguistics and modern languages are but two.

SAN ANTONIO MEDICAL SCHOOL

I. Docket, Page ST-2, Item #1 under Recommended Budget Changes

Office of Media & Community Information

Appoint Miss Marjorie A. Clapp as Assistant to the Director of Media & Community Information at an annual salary rate of \$12,500 effective September 1, 1971. (RBC# 33)

EXCEPTION COMMENT:

Is Miss Clapp with or without tenure, and how many such writers are required by this System?

RESPONSE:

Miss Clapp does not have tenure. San Antonio has one science writer, and she serves the medical, dental, and nursing schools. In the System, there are 22 writers, both science and general. M. D. Anderson will add one in January, bringing the total to 23. The System Administration has one person with writing (news and information) responsibility.

II. Docket, Page ST-4, Item #27 under Recommended Budget Changes

Psychiatry

Correct the status of Dr. Orie L. Forbis, Jr. from Associate Professor (T) to Associate Professor (without tenure) at an annual salary rate of \$26,500 effective September 1, 1971. (RBC# 6)

EXCEPTION COMMENT:

Please explain how you retract tenure.

RESPONSE:

In this case tenure is not being removed. This is to correct a clerical error in the 1971-72 operating budget. Dr. Forbis was never notified that he had been granted tenure since there was never any intention to give him tenure.

HOUSTON MEDICAL SCHOOL

I. Docket, Pages HO-2, HO-3, HO-4, HO-5 under Recommended Budget Changes

Transfer of Funds

From: Various Departmental Unexpended Appropriation  
Balances - Net (as of August 31, 1971)

To: Departmental Equipment

EXCEPTION COMMENT:

Total travel of \$33,541.32 budgeted and apparently not used and transferred as shown on Page HO-5, with no allowance for travel, or is it covered up in some other item?

RESPONSE:

Inasmuch as the Houston Medical School is funded primarily from General Revenue and rider provisions in House Bill No. 2 permit free transferability among the line-item appropriation and the reappropriation of unexpended balances from the fiscal year 1971 to 1972, this closing adjustment was prepared to group such funds into "departmental equipment items" for forwarding into the new fiscal year.



PUBLIC HEALTH SCHOOL

I. Docket, Page PH-6 under Recommended Budget Changes

Population Studies

Reappointment

Reappoint Dr. Robert E. Roberts, Associate Research Demographer, payable at \$11,000.00 per annum for 50% time from Population Studies (General Funds), \$5,500.00 per annum for 25% time from Kaiser Foundation Hospital Grant and \$5,500.00 per annum for 25% time from Regional Medical Program Grant 2-G03-RM-00007-04, Project 1016, effective September 1, 1971. (RBC 36 and 48)

EXCEPTION COMMENT:

Under Population Studies: Just what sort of population studies is the Kaiser Foundation interested in, since they are granting the funds for such a study? And what is the ultimate goal of the researchers?

RESPONSE:

Dr. Robert E. Roberts is paid from three fund sources for fractions of his time. The Kaiser Foundation supports the individual rather than the population studies project, which is financed from general budget funds.

The document supporting the Request for Legislative Appropriations for the biennium 1972 and 1973 includes the attached summary relating to areas of disciplinary emphasis. Item one is "Population Studies."

THE UNIVERSITY OF TEXAS  
SCHOOL OF PUBLIC HEALTH  
ADMINISTRATOR'S STATEMENT

In order to serve the needs of students and of the community at large, the School of Public Health has adopted an administrative structure which is planned around the major problems in community health, in contrast to the more common pattern of organization that emphasizes disciplinary identity. According to this view, each of the problem areas requires participation by administrators, behavioral scientists, epidemiologists, and biostatisticians, as well as other specialists.

The problem-oriented units may change direction from time to time, in order to be responsive to the rapid changes in our environment and society. However, at this time we have eight such units in the organization plan.

1. Population Studies. The rapid growth of population lies at the root of many of our most pressing concerns in health. This field of study includes demography, reproduction physiology, family planning. The great increase in concern for population growth is creating a serious need for persons trained to plan and conduct community-based programs as well as persons qualified to pursue research on the density and distribution of human populations.

2. Nutrition. In Texas, as elsewhere in the United States, we are now observing simultaneously the health effects of over-nutrition, malnutrition, and under-nutrition. A large number of specific disease entities are linked to nutrition, from severe diarrhea in under-nourished infants to heart disease in over-nourished middle-aged executives. Again, both research and program activities are required, and this calls for administrators, physicians, biostatisticians, biochemists, and others.

3. Urban Health. The heavy concentration of our population in urban places establishes a need for specific attention to be paid to the health of urban dwellers. In the cities many problems are magnified and accentuated by the sheer pressure of numbers of people in limited space. Urban planning centers have been established at many universities, but notably lacking in these centers is specific attention to health. Although we cannot, and do not, propose to develop a comprehensive activity in urban planning, we do believe that the specific health-related aspects are so important that we must devote substantial effort to them. The Urban Health is concerned with urban design, health services systems applicable to urban settings, and some special aspects of management of urban environments. These all inter-relate closely with the activities of other units of the School, but this unit is distinguished by special emphasis on and direction toward urban affairs.

4. Health Services. In this unit we have grouped the activities ordinarily carried on in departments of public health administration, medical care administration, comprehensive health planning, and similar titles. Our concerns include the planning and administration of public health services of a traditional kind, but also the systems for provision of personal health services. Thus, health surveillance, program planning and evaluation, lay and professional education, management methods, systems analysis, and the study of manpower, facilities, and health economics are some of the functions treated by the faculty and students in this unit.

THE UNIVERSITY OF TEXAS  
SCHOOL OF PUBLIC HEALTH  
ADMINISTRATOR'S STATEMENT

5. Environmental Health. Among the more significant problems confronting us are those related to the serious degradation of the environment in which we live. In a very acute way these concerns strike at matters basic to survival--such vital concerns as the quantity and quality of air, water, and space. The accelerating development of technical capabilities and methods confronts us with an ever-changing but increasing flood of toxic materials that present special hazards to special occupations and often are released widely into the environment.

6. International and Ethnic Studies. Repeatedly in dealing with health problems, the difficulty of transferring technical and scientific information and procedures across cultural boundaries comes centrally into focus. Differences in language, customs, attitudes, values, and ways of thinking all act as deterrents to the optimal application of knowledge for the benefit of subsets of our own population as well as people of other countries. Comparative studies of community health in different cultures are critically important.

7. Infectious Disease. Despite the great success that has attended infectious disease control activities in the past one hundred years, many serious problems remain. To understand them and develop ways to deal with them require the efforts of microbiologists, entomologists, parasitologists, epidemiologists, and people who are experts in disease control programs.

8. Chronic Disease. The relative decline in importance of infectious diseases has been accompanied by an enormous increase in non-infectious diseases as major causes of morbidity and mortality. Again, a diversity of skills and talents are required to develop methods for the control of heart disease, arthritis, stroke, cancer, and mental illness.

PUBLIC HEALTH SCHOOL

II. No Docket Reference.

EXCEPTION COMMENT:

Under the School of Public Health, I would like a breakdown in general terms as to the student body, how many attorneys and other such people constitute this body.

RESPONSE:

Breakdown of School of Public Health student body:

218 Students Enrolled:

116 males  
102 females

Ethnic Groups

208 U. S. nationals:  
4 Oriental  
17 Black  
2 Mexican-American  
1 Puerto Rican  
184 Other White  
  
10 foreign nationals

By prior professional discipline:

13 M.D.  
5 D.V.M.  
5 D.D.S.  
2 O.D.  
2 J.D.  
30 nurses  
4 pharmacists  
3 architects  
3 engineers

214 Degree Candidates:

111 M.P.H.  
23 M.S.

134 Masters candidates

37 D.P.H.  
24 Ph.D.

61 Doctor degree candidates

19 not registered for specific degree

GENERAL COMMENT

I. No Docket Reference

Subject:

Faculty with Tenure

EXCEPTION COMMENT:

I should like to suggest that all faculty with tenure be listed, along with length of tenure and that the Chancellor's Docket be revised, since all schools do not report their appointments or re-appointments with or without tenure in one general section, so that members of the Board would not have to search out each individual and then wonder whether they have tenure or not.

RESPONSE:

Regent Nelson's suggestion that all faculty tenure considerations be separately designated comes at a time when the entire format and administrative approval procedure of the Chancellor's Docket is under review. The clear designation of new proposed tenure action will be foremost in the recommendations to be submitted for Board approval in January.

ACADEMIC AND DEVELOPMENTAL AFFAIRS COMMITTEE

Date: December 3, 1971

Time: Following the meeting of the Executive Committee

Place: Main Building, Room 212  
The University of Texas at Austin  
Austin, Texas

	<u>Page A &amp; D</u>
1. U. T. System: Chancellor's Docket No. 52	1
2. U. T. Austin: Enrollment Control	2
3. U. T. Austin, U. T. El Paso, U. T. Arlington and U. T. Dallas: Ratification of Resolution with Respect to Minimum Standard Teaching Load Requirements	15
4. U. T. Austin, U. T. El Paso, U. T. Arlington and U. T. Dallas: Proposed U. T. System Minimum Teaching Workload Standards	16
5. U. T. Dallas, San Antonio Medical School, Galveston Medical Branch and Public Health School: Dual Positions Pursuant to Article 6252-9a, Vernon's Texas Civil Statutes	29

- 
1. U. T. System: Chancellor's Docket No. 52. --Chancellor's Docket No. 52 was mailed by the Secretary to each member of the Board of Regents on Thursday, November 11, 1971. The ballots are due in the Secretary's Office at the close of business on November 30, 1971. If there are exceptions to the docket they will be reported at the meeting of the Academic and Developmental Affairs Committee and referred to the Committee of the Whole for consideration. Otherwise, the docket will be presented for formal approval.

2. U. T. Austin: Enrollment Control (Pages 2 - 14). --

Chancellor LeMaistre concurs in President Spurr's recommendations concerning the provisions for enrollment control at U.T. Austin for the academic year 1972-73 and recommends Board approval.

I. It is recommended that the following procedures, which correspond exactly to those previously approved by the Regents for the academic year 1971-72, be approved for the academic year 1972-73:

1. New Freshmen who qualify for admission will be admitted to U.T. Austin for the academic year 1972-73 under the following procedures:

- A. For the fall semester only, a quota of 5500, the same as the quota for 1971-72, will be in effect. Applicants admitted under this quota may begin in the 1972 Summer Session if they choose to do so.
- B. Application periods, with specified deadlines, for both fall and spring semesters will apply. All students applying during the application period for the fall semester will be considered for admission under the 5500 quota in accordance with the Board of Regents procedures established in December 1970 for making offers of acceptance. Applications received after this priority period will be considered under the same procedures if positions remain available within the 5500 quota. A deadline for the acceptance of the admissions offer will be set with the requirement that a tuition deposit be made with acceptance of the offer of admission.
- C. For the fall semester only, preference will be given to applicants in the following order:
  1. All applicants who were in the top 10% of their high school classes.
  2. All qualified applicants who were in the top quarter, but not top 10%, of their high school classes.
  3. All qualified applicants who will receive competitive scholarships recognized by U.T. Austin.
  4. All qualified applicants from the other three quarters of their high school classes will be placed in a pool. If the number of applicants exceeds the quota, random selection will be used to make offers of acceptance.

2. Lower-Division Transfers will be admitted to U.T. Austin for the academic year 1972-73 under the following procedures:

- A. For the fall semester only, a quota of 1300, the same as the quota for 1971-72, will be in effect. Applicants admitted under this quota may begin in the 1972 Summer Session if they choose to do so.
- B. Application periods, with specified deadlines, for both fall and spring semesters will apply. All students applying during the application period for the fall semester will be considered for admission under the 1300 quota and in accordance with the procedures established by the Board of Regents in December 1970 for making offers of acceptance. Applications received after this priority period will be considered under the same procedures if positions remain available within the 1300 quota. A deadline for the acceptance of the admissions offer will be set with the requirement that a tuition deposit be made with acceptance of the offer of admission.
- C. For the fall semester only, preference will be given to applicants who meet the current admission requirements on the basis of a weighted combination of their cumulative grade point averages and the number of semester hours of credit previously earned. The same procedures and the Admissions Index adopted by the Board of Regents on December 4, 1970 will be used to calculate the points for admission of lower-division transfer students. Random selection will be used to make offers of acceptance if the number of applicants exceeds the quota, in accordance with the procedures approved by the Board of Regents on December 4, 1970.

II. In accordance with the Resolution adopted by the Board of Regents on October 23, 1970 directing that enrollment controls be developed for both upper-division and lower-division levels, it is recommended that the procedures below for controlling enrollment of upper-division transfer students be approved to apply for the academic year 1972-73. It is considered desirable to establish this procedure in anticipation of a substantial increase in upper-division transfers in future years. The establishment of this procedure at this time will provide for placing it in operation and testing and evaluating it. The installation of the procedure at this time will hopefully avoid problems that might result from hastily placing a control on upper-division transfers when the problem becomes acute.

- 1. For the fall semester only, a quota of 3900, a figure approximately 500 above the number of upper-division transfers in 1971-72, will be in effect. Applicants admitted under this quota may begin in the 1972 Summer Session if they choose to do so.



2. Application periods, with specified deadlines, for both fall and spring semesters will apply. All students applying during the application period for the fall semester will be considered for admission under the 3900 quota and in accordance with the procedures described under Item 3 below. Applications received after this priority period will be considered under the same procedures if positions remain available within the 3900 quota. A deadline for acceptance of the admissions offer will be set with the requirement that a tuition deposit be made with acceptance of the offer of admission.
3. For the fall semester only, preference will be given to Texas residents who are transferring from junior colleges (and from senior colleges for those students transferring into professional degree programs at U.T. Austin) who meet current admission requirements. If necessary, random selection will be used to determine admission of other applicants who meet current admission requirements.

III. It is recommended that U.T. Austin be authorized to extend initially offers of acceptance to 110% of the established quota in each category described above if applications exceed the quota in any category. The experience last year was that approximately 15% of the applicants declined offers of acceptance, and the delay in responses resulted unfortunately in extending the period of making offers to other students in the priority order of ranking. This authorization should expedite the making of offers and the formalization of acceptances without undue risk to exceeding the established quotas.

President Spurr also reports for the record on two items which do not require Board of Regents' action.

1. In view of the continuing concern about the inadequacies of the use of admission standards for freshmen based solely on SAT scores and high school rankings, President Spurr has appointed a committee to develop ways and means of identifying and evaluating students for admission based on other criteria which would predict the ability of students to do creditable college-level work. As stated in his letter of November 5, he does not agree with the faculty recommendation that a sub-quota be established within the 5500 over-all quota for such students. Dr. Spurr hopes to develop a proposal for dealing with this issue for later submission to the Board of Regents.
2. President Spurr proposes to use two existing programs, "Project Info" and "From Campus to Counselor," to increase the visitation and information programs to inform high school students, teachers, and counselors about U.T. Austin. These programs will be carried out in compliance with the restrictions against recruitment contained in the Board policy on admissions in Section 6, Chapter I, Part Two, of the Rules and Regulations.



THE UNIVERSITY OF TEXAS AT AUSTIN  
OFFICE OF THE PRESIDENT  
AUSTIN, TEXAS 78712

November 5, 1971

Charles A. LeMaistre, M.D.  
Chancellor  
The University of Texas System

Dear Dr. LeMaistre:

At its meeting on October 18, 1971, the University Council adopted a set of recommendations for enrollment control at The University of Texas at Austin for the academic year 1972-73. At its previous meeting on September 20, the Council had adopted other recommendations, also pertinent to the general issue of enrollment control, to establish a visitation program among Texas high schools and to amend certain admission provisions for a portion of those to be admitted as new freshmen next year. May I hereby transmit both Council actions to you (D&P 4924-26, 4930-31).

With respect to the enrollment control plan for the coming academic year, I recommend the following:

- (1) The continuation of the enrollment control quotas and procedures in effect this current year for new freshmen and new lower-division transfer students as approved by the Board of Regents on October 23 and December 4, 1970.
- (2) The establishment of a quota of 3,900 new upper-division transfer students for the coming fall semester, the administration of this quota to be under the same general type of procedures as recommended by the University Council.

On the basis of our enrollment experience this semester, and in the absence of any major shift in enrollment

patterns next fall, this quota of 3,900 students will probably not exclude any qualified upper-division transfer student who applies for admission for the summer or fall of 1972. In all likelihood, however, we shall continue to experience growth in the number of admissions applications from upper-division transfer students in future years. Support for this expectation may be found in the enrollment increases in Texas junior colleges this fall. Rather than wait until such enrollment pressures appear on the Austin campus, we think it highly desirable to establish and administratively test quota provisions for upper-division transfer students at this time.

Included within the University Council's legislation of October 18, 1971, is the proposal that UT Austin be authorized to develop, under an overall quota for upper-division transfer students, separate quotas for each college, school and division for future years. It would seem unnecessary to request this particular authority at the present time. An analysis of such separate quotas has already begun at the college and school level. When this work is completed, specific recommendations will be submitted for your consideration and that of the Board of Regents.

- (3) Authorization for The University of Texas at Austin to issue admission offers of up to, but not more than, 110% of the quota for new freshmen, new lower-division transfer students, and new upper-division transfer students at the end of the initial priority application periods for each of these categories.

In administering the enrollment control plan last spring and summer, we experienced a situation within which significant numbers of students sent admission offers under that plan subsequently declined those offers. There were, of course, many reasons behind these declinations and in no sense was our experience unexpected. The structure of our enrollment controls, however, produced an undesirable side effect. Many qualified applicants could not be admitted until open-

ings were generated within the quota by rejections of offers mailed earlier. Thus, while we were ultimately able to grant admission to all qualified applicants, many were not informed of their acceptance until late spring or early summer. These students and their families were placed in a very uncertain position by being forced to wait a considerable period of time before being notified.

Should the enrollment control plan for 1972-73 be adopted without modification, we shall undoubtedly repeat this experience next spring. If, however, we are allowed to administer the admissions process by making initial offers in excess of the quotas, not only will hundreds of students be inconvenienced but the ultimate enrollment of new freshmen and new transfer students will undoubtedly be well within the established quotas.

In my opinion, the University Council's legislation of September 20, 1971, does not require Regental action at this time. I share the Council's view that total reliance on high school ranking and test scores as admissions qualifications can result in excluding students who are fully capable of performing satisfactorily at the college level. I do not feel, however, that any precise sub-quota for these students would be appropriate. In fairness to all those meeting current admissions standards, no adjustment should be made in the ways by which the quota of 5,500 new freshmen is filled.

I have established a special faculty-student committee chaired by Dr. Paul Kelley, Director of the Measurement and Evaluation Center, to explore ways and means of identifying and evaluating those individuals from economically and educationally deprived backgrounds who have the potential to succeed in college but who may not be fully identified simply by S.A.T. scores and high school ranking. While this committee has no authority in the area of admissions decisions, its efforts should provide a basis upon which specific recommendations can be formulated and submitted to you and the Board of Regents. Hopefully, this can be accomplished in time to be effective for the fall of 1972.

There are two means by which we can achieve the objectives underlying the Council's request that the University "establish and engage in an intensive visitation program directed toward informing Texas high school students, teachers and counselors of educational opportunities at the University and the criteria for and the means of admission to the University." The first, of course, is Project Info, an extremely valuable program previously authorized by the Regents and conducted by the University. The second is our "From Campus to Counselor" program under the direction of Vice President Ronald M. Brown. This particular program has been expanded this year to include four workshops to be conducted in Austin, Dallas, Houston and McAllen. Both programs will be administered in strict accordance with the Rules and Regulations of the Board of Regents.

Sincerely yours,

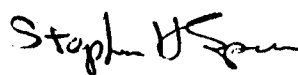

Stephen H. Spurr  
President

THE UNIVERSITY OF TEXAS AT AUSTIN  
AUSTIN, TEXAS 78712

PRESIDENT'S OFFICE U. T. AUSTIN	
REC'D	OCT 20 1971
REFER TO _____	
HANDLE _____	
COMMENT & RETURN _____	
FILE OR DISCARD _____	

October 20, 1971

Dr. Stephen H. Spurr, President  
The University of Texas at Austin  
Main Building 102

Dear Dr. Spurr:

The University Council on October 18, 1971 amended and adopted the recommendations for enrollment control at U.T. Austin for the academic year 1972-73 which had been prepared by the Enrollment Control Task Force and had been approved by the Faculty Senate on October 4, 1971.

The amendment affected only recommendation C (Upper Division Transfers), paragraph 3 by adding the language in parentheses shown below. As amended, this paragraph in its entirety reads:

3. For the Fall Semester only, preference will be given to Texas residents who are transferring from junior colleges (and senior colleges for those students transferring into professional degree programs at U.T. Austin) and who meet current admission requirements. If necessary, random selection will be used to determine admission of other applicants who meet our current admission requirements.

I enclose two copies of these recommendations marked to show the amendment made by the University Council (D&P 4930-31).

These recommendations as amended and adopted by the Council are now ready for your further consideration. I presume that you will want to transmit them to the Chancellor along with your own recommendations.

In your letter of October 4, 1971 to me, you indicated that you intended to hold the impending action of the University Council on certain proposals submitted by the Admissions and Registration Committee (D&P 4924-26) in order to combine them with the Council's recommendations on enrollment control, submitting together these two sets of recommendations, along with your own recommendations, for consideration by the Board of Regents at its December meeting. In my letter to you on September 22, 1971 I indicated that the Council had amended and adopted the proposals of the Admissions and Registration Committee.

Sincerely yours

*Forest G. Hill*

Forest G. Hill, Secretary  
The University Council

Enc.

## DOCUMENTS AND PROCEEDINGS OF THE UNIVERSITY COUNCIL

RECOMMENDATIONS FOR ENROLLMENT CONTROL AT U.T. AUSTINFOR THE ACADEMIC YEAR 1972-73

Mr. Wright, Chairman of the Faculty Senate, has filed with the Secretary of the University Council the recommendations published below. The Secretary has classified these proposals to be minor legislation.

Notice is hereby given that this legislation will be presented to the University Council for consideration at its meeting of October 18, 1971.

Forest G. Hill, Secretary  
The University Council

RECOMMENDATIONS OF THE FACULTY SENATE

The Faculty Senate on October 4, 1971 adopted without alteration and now recommends that the University Council adopt the recommendations of the Enrollment Control Task Force reproduced below.

RECOMMENDATIONS OF THE ENROLLMENT CONTROL TASK FORCEFORENROLLMENT CONTROL AT UT AUSTIN FOR THE ACADEMIC YEAR 1972-73

Based on recommendations submitted to the President by the Admissions and Registration Committee, the Task Force on Enrollment Control recommends that enrollment control policies be adopted by The University of Texas at Austin for the academic year 1972-73 which are in keeping with, and an extension of, the enrollment control policies already in effect for the academic year 1971-72. The recommendations of the Task Force for 1972-73 include the affixing of numerical quotas to the admission of new freshmen, lower-division transfers, and upper-division transfers.

The Task Force joins with the Admissions and Registration Committee in recommending that an extensive evaluation study of the effects of the enrollment control policies be conducted during 1972-73, the second year of implementation, so that necessary or desirable modifications may be undertaken.

Until the experience of the Spring Semester of 1971-72 has been determined, no recommendations are made concerning possible numerical quotas for the Spring Semester of 1972-73.

RECOMMENDATIONS

- A. New Freshmen. The admission of new freshmen to UT Austin for the academic year 1972-73 shall be under the same general procedures used for 1971-72. The principal elements of these procedures will be:
1. Application periods, with specified deadlines, for both Fall and Spring semesters. The application period for the Fall Semester would be composed of:
    - a. A priority application period.
    - b. A subsequent non-priority application period.
  2. For the Fall Semester only, a quota of 5500, the same as the quota for 1971-72. (Applicants admitted under this quota may begin in the 1972 Summer Session if they choose to do so.)

3. For the Fall Semester only, preference is given to applicants who:
  - a. Were in the top 10% of their high school classes.
  - b. Were in the top quarter, but not top 10%, of their high school classes and who meet the current admission requirements.
  - c. Will receive competitive scholarships and who meet current admission requirements.

If necessary, random selection will be used to determine admission of other applicants who meet our current admission requirements.

4. A deadline for the acceptance of the admissions offer.

B. Lower Division Transfers. The admission of lower division transfers to UT Austin for the academic year 1972-73 shall be under the same general procedures used for 1971-72. The principal elements of these procedures will be:

1. Application periods, with specified deadlines for both Fall and Spring Semesters. The application period for the Fall Semester will be composed of:
  - a. A priority application period.
  - b. A subsequent non-priority application period.
2. For the Fall Semester only, a quota of 1300, the same as the quota for 1971-72. (Applicants admitted under this quota may begin in the 1972 Summer Session if they choose to do so.)
3. For the Fall Semester only, preference is given to applicants who meet the current admission requirements on the basis of a weighted combination of their cumulative grade-point averages and the number of semester hours of credit previously earned. If necessary, random selection will be used to determine admission of other applicants who meet our current admission requirements.
4. A deadline for the acceptance of the admission offer.

C. Upper Division Transfers. The admission of upper division transfers to UT Austin for the academic year 1972-73 shall be under the same general type of procedures used for admitting lower division students. The principal elements of these procedures will be:

1. Application periods, with specified deadlines, for both Fall and Spring Semesters. The application period for the Fall Semester will be composed of:
  - a. A priority application period.
  - b. A subsequent non-priority application period.
2. For the Fall Semester only, a quota of 3900, the same as the number of upper division transfers expected in 1971-72. Applicants admitted under this quota may begin in the 1972 Summer Session if they choose to do so. It is further proposed that UT Austin be authorized to develop, under an over-all quota, separate quotas for each college, school, and division for future years.
3. For the Fall Semester only, preference will be given to Texas residents who are transferring from junior colleges and who meet current admission requirements. If necessary, random selection will be used to determine admission of other applicants who meet our current admission requirements. (and senior colleges for those students transferring into professional degree programs at U.T. Austin)
4. A deadline for the acceptance of the admission offer.

F. Lanier Cox  
Peter T. Flawn  
Gerhard J. Fonken  
Lester Harrell

D. B. J. Holland  
Robert D. Mettlen  
W. Byron Shipp  
Andrew C. Stedry  
H. Paul Kelley, Chairman

Filed with the Secretary of the University Council by Mr. Charles Alan Wright, Chairman of the Faculty Senate, on October 6, 1971. Distributed among the members of the University Council on October 13, 1971.

THE UNIVERSITY OF TEXAS AT AUSTIN

AUSTIN, TEXAS 78712

PRESIDENT'S OFFICE  
U.T. AUSTIN

REC'D SEP 23 1971

REFER TO E.O.M.

HANDLE          READ & RETURN         

September 22, 1971

President Stephen H. Spurr  
The University of Texas at Austin  
Main B. 102

Dear Dr. Spurr:

The University Council on September 20, 1971 adopted (with one amendment, as indicated below) the proposals of the Admissions and Registration Committee that the University (1) establish a visitation program among Texas high schools and (2) amend its admission provisions for a portion of the freshmen admitted (D&P 4924-26--two copies enclosed, with the amendment indicated thereon). The amendment affects only the first sentence of item B in recommendation II on D&P page 4924. This sentence was amended to read as follows:

The application must be accompanied by such additional evidence and information, from high school teachers, counselors, principals, or other persons, as the applicant may deem desirable.

This legislation is now ready for your action with respect to approval and submission to the Board of Regents.

Sincerely yours

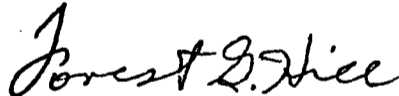

Forest G. Hill, Secretary  
The University Council



## DOCUMENTS AND PROCEEDINGS OF THE UNIVERSITY COUNCIL

PROPOSALS THAT THE UNIVERSITY (1) ESTABLISH A VISITATION PROGRAM AMONG  
TEXAS HIGH SCHOOLS AND (2) AMEND ITS ADMISSION PROVISIONS FOR A  
PORTION OF THE FRESHMEN ADMITTED

Mr. G. J. Fonken, chairman of the Admissions and Registration Committee, has filed with the Secretary of the University Council the recommendations set forth below. The Secretary has classified these proposals as minor legislation.

Notice is hereby given that this legislation will be presented to the University Council for consideration at its meeting of September 20, 1971.

*Forest G. Hill*

Forest G. Hill, Secretary  
The University Council

RECOMMENDATIONS OF THE ADMISSIONS AND REGISTRATION COMMITTEE

The Admissions and Registration Committee recommends that:

- I. The University establish and engage in an intensive visitation program directed toward informing Texas high school students, teachers and counselors of educational opportunities at the University and the criteria for and means of admission to the University. The program should give particular emphasis to those high schools and school districts which, by common recognition, have not matriculated significant numbers of students in the University in recent years. It is further recommended that funding for such a program be sought from sources other than state-appropriated monies and that the funding and administration of the program be so implemented as to conform with Regents' Rules and Regulations, Part Two, Chapter I, Section 6, "General Admission Policy."

In the implementation of the proposed program it is suggested that, wherever possible, those persons participating in the visitations should be selected on the basis of their sensitivity to and understanding of the nature of the high school or school district which is being visited and any unique sociological or economic aspects of the community which is served by the school. Such discerning selection is intended to ensure maximum and best directed import of information on such particular matters as financial aid opportunities, special educational provisions, provisional admission programs and other matters whose importance to high school populations may vary from one community to another.

- II. The University admissions provisions be amended so that not more than 10% of the existent admission quota for new freshmen may be filled with applicants who are residents of Texas and who meet only the following qualifications:

A. The applicant must graduate in the upper 50% of his high school class and meet the current unit requirements.

B. The application must be accompanied by ~~the endorsements of the high school counselor or principal and two high school teachers and of such~~ other persons, as the applicant may deem desirable. Such endorsements must indicate, in terms of objective criteria, why the endorser feels the applicant to possess abilities that would enable him or her to do creditable college work.

*such additional evidence and information, from high school teachers, counselors, principals, or*

- C. Furthermore, the endorsements must indicate satisfactory reasons why the applicant could not otherwise seek or gain admission to the University.

Applications for admission under the proposed provisions should be screened by and subject to the approval of a selected admissions committee comprised of faculty, a representative from the Measurement and Evaluation Center, and the Registrar or his delegate.

### Background and Explanation

#### Recommendation I

The University is heavily burdened by having to develop services for the enormous number and variety of people in the State who need and want to be served by it. In this respect, the Admissions and Registration Committee feels that it is incumbent upon the University to effectively provide all information relevant to the services it offers and to the ways and means by which the public may avail themselves of such services. A most pertinent matter within this context is the providing of potential students with a sound basis for effecting decisions concerning their intended educational development through higher education. At present, a prospective student depends heavily upon that information which is revealed to him by high school counselors, the University catalog, and such adventitious sources as may be available to him. Much information, so obtained, will have little meaning either to the prospective student or to his parents unless it is expertly interpreted.

The proposed visitation program is intended to be directed at providing prospective students with and insuring them of the soundest and most complete possible basis for decision making and implementation so that their best interests are served.

#### Recommendation II

The current University admission provisions for new freshmen are, for the most part, based upon the high school class ranking and/or the entrance examination or admissions test performance of the applicant. In recent years, many persons, groups, and organizations have raised the question of whether such criteria do, of themselves, serve effectively as the sole admissions selection factors for those students who in the broadest sense are the most promising. By advancing the accompanying recommendations, the Admissions and Registration Committee holds that they do not. In support of its view, the Committee has taken note of recommendations of the College Entrance Examination Board Commission on Tests\* which suggest that the Board endeavor to provide informational services for such auxiliary or alternative admission evaluation factors as:

1. Student performance on achievement tests.
2. Assessment of non-academic achievement such as coping skills, avocational skills, social competence, artistic, athletic and mechanical skills.
3. Sources and status of student motivation.
4. Student work habits and task involvements under varied conditions of demand.
5. Comprehension through experiencing and listening as well as reading.
6. Student ability in problem solving in situations that require varied cognitive skills and styles.

---

\*Report of the Commission on Tests: II. Briefs Published by CEEB, New York, 1970.

7. Expressions through artistic, oral, non-verbal and graphic symbolization.
8. Student adaptation to new learning situations.

The Admissions and Registration Committee is of the opinion that many prospective students may have a considerable range of special skills and desirable characteristics which are masked by the admissions tests and that the University therefore fails to obtain a full view of the individual capabilities of many prospective promising students. The Committee, in its second recommendation, therefore suggests the adoption of a means of admission which would de-emphasize the weighting given to admission test scores and would accordingly give weight to individual evaluation factors and supporting evidence in the selection process.

3. U. T. Austin, U. T. El Paso, U. T. Arlington and U. T. Dallas:  
Ratification of Resolution with Respect to Minimum Standard Teaching  
Load Requirements - Action to Be Taken on December 3, 1971. --  
The following resolution was approved at the meeting on  
October 22, 1971, however, this proposal was not on the  
agenda for the October 22nd meeting and it is resubmitted  
for ratification:

WHEREAS, The Legislature has plainly indicated its concern at appropriation levels for faculties, size of classes, outside employment and income, and minimum teaching workloads;

WHEREAS, The Board of Regents is required by law to establish "minimum standard teaching load requirements" in the general academic institutions of the U. T. System;

WHEREAS, The administrations of the U. T. System and the institutions have been directed by the Board to prepare such standards in consultation with the faculties for recommendation to the Board;

NOW, THEREFORE, BE IT RESOLVED, That the Board of Regents solicits the cooperation of the faculties in increasing teaching workloads where appropriate and necessary; and

BE IT FURTHER RESOLVED, That the Board of Regents proposes to meet its legal requirements at its December 3 meeting to be applied to the Spring Semester and that the institutional heads be requested to communicate this resolution to all faculty members at their institutions.

4. U. T. Austin, U. T. El Paso, U. T. Arlington and U. T. Dallas:  
Proposed Minimum Teaching Workload Standards (Pages 16 - 28). --

The U.T. System Administration recommends approval of the Minimum Teaching Workload Standards as set forth below for use in each of the general academic institutions in the U.T. System.

Work to establish standards began last summer after passage of the State Appropriations Bill, which required that such standards be adopted. The Board of Regents on July 30 referred the standards recommended at that time back to the U.T. System Administration and directed the institutions to collect faculty workload data on the fall semester to be used by them and the U.T. System as a basis for developing standards to be applied in the spring 1972 semester. Several different approaches were developed by the System Administration and the institutions.

Since the October 22 meeting, all institutions have submitted recommendations for developing standards to apply System-wide. The standards recommended below are based on a proposal submitted by U.T. Austin as modified by the U.T. System Administration. The proposed standards below have been reviewed with Presidents Harrison, Jordan, and Smiley and are acceptable to them. Both Presidents Harrison and Smiley feel that these standards are far superior to the guidelines previously recommended to the Board of Regents. President Spurr believes the standards proposed can be used at U.T. Austin if a System-wide standard must be applied. However, he recommends that the unique nature of U.T. Austin should be recognized and that a three-course load rather than four should be applied to U.T. Austin.

It is the opinion of the U.T. System Administration that the standards recommended for adoption do provide a mechanism for effectively measuring teaching activities at the several institutions while recognizing within the U.T. System the different types of institutions and their different mixes in graduate and undergraduate teaching. It seems very unlikely that U.T. Austin or any other institution in the U.T. System will be injured in its academic work under the standards recommended since they provide for recognizing the differences in the magnitude of graduate work done in each institution. It is the further opinion of the U.T. System Administration that the use of these standards will result in (1) a more equitable distribution of teaching loads among faculty members, (2) an increase in teaching activities by some faculty members, and (3) a demonstrable increase in the aggregate in teaching among the existing faculties.

In summary, the proposed standards require a minimum teaching load of four normal undergraduate courses with special types of teaching activities equated against an undergraduate course to give recognition to large classes, classes requiring more or less class contact hours than is normal, graduate classes, individual instruction, supervision of doctoral and master's theses, and formal academic administrative assignments.

MINIMUM FACULTY WORKLOAD STANDARDS  
GENERAL ACADEMIC INSTITUTIONS  
THE UNIVERSITY OF TEXAS SYSTEM

- I. In compliance with the requirements of the Appropriations Bill of the 62nd Texas State Legislature, each general academic institution in The University of Texas System shall file with the Chancellor a teaching load report within 30 days after the close of registration for the fall and spring semesters to show compliance of each teacher with the minimum standard teaching load requirements set forth below. The Chancellor shall file these reports with the Board of Regents and the Secretary to the Board, and copies will be made available for public inspection in the Office of the Chancellor.
  
- II. The basic faculty workload unit shall be the three-hour undergraduate course with an enrollment of at least ten students. The minimum faculty workload for the general academic institutions in The University of Texas System shall be four courses.
  
- III. Course credit may be given for other teaching and teaching-related activities, and courses may be waived by the President for academic administrative assignments as set forth under V below. All faculty members shall teach at least two organized courses, except in those departments, schools, or colleges where teaching is traditionally and appropriately by individual instruction or as courses are waived for academic administrative assignments.
  
- IV. The calculation of faculty workloads will be made as follows:
  - A. For a faculty member who has less than a full-time appointment or who is budgeted for less than 100% of his salary from "Teaching Salaries," the minimum workload will be reduced proportionately.
  - B. Fractions of course credits may be combined to arrive at a total workload.

- C. In the case of courses with regular scheduled classroom contact less than or more than the three hours of the standard course, credit will be calculated on the basis of the number of classroom contact hours met by the instructor, and counted as three regular scheduled contact hours equivalent to one course. In those cases where laboratory or discussion or review sessions are regularly scheduled in addition to the classroom contact hours for a particular course, and are met by the same instructor, not more than one course credit shall be given for these additional contact hours.
- D. In the case of large undergraduate classes, extra course credit will be given as follows:
1. Classes containing more than 100 students and less than 300 students will be counted as one and one-half courses.
  2. Classes containing 300 students or more will be counted as two courses.
- E. An organized three-hour graduate class with an enrollment of five to 59 students will be the equivalent of one and one-half courses, so that two such graduate courses will be the equivalent of three standard undergraduate courses. An organized three-hour graduate class with an enrollment of 60 or more students will count as two courses.
- F. In order for course credit to be given for teaching a small class (undergraduate enrollment of less than ten or graduate enrollment of less than five), the offering of the class must be approved by the President, provided, however, that no graduate class of less than five students will receive more than one course credit.
- G. Ten undergraduate students enrolled in individual instruction courses carrying three semester hours credit will be the equivalent of one course.
- H. Five graduate students enrolled in individual instruction courses (exclusive of thesis or dissertation courses) carrying three semester hours credit will be the equivalent of one course.

- I. For applied music instruction, 4.5 registered students shall be the equivalent of one standard course.
- J. For student-teacher supervision, 4.5 students will be the equivalent of one standard course.
- K. Where classes are conducted by organized group instruction, such as in architecture, art, and drama, 4.5 contact hours per week of such instruction will be the equivalent of one course.
- L. A faculty member engaged in graduate student supervision may receive course credit for up to but not more than two courses as follows:
  - 1. Chairmanship of three doctoral student committees for registered students shall be the equivalent of one course (maximum three years).
  - 2. Chairmanship of five masters student committees for registered students shall be the equivalent of one course (maximum two years).
  - 3. Membership in ten graduate student supervising committees for registered graduate students shall be equivalent to one course (maximum three years for doctoral students, two years for masters students).

Graduate students must be registered in appropriate thesis and dissertation courses in order for credit to be counted in computing faculty workload. Supervisors may not receive credit both under this item and under individual instruction courses for the same student.
- M. For any course taught jointly by more than one teacher or to which more than one teacher is assigned or claiming credit, the course value of the class will be calculated in accordance with the foregoing sections and will be distributed among the faculty members involved.
- N. When two courses are combined under one faculty member or he schedules two courses to meet together, he may not receive credit for more than one of the courses.



- O. Courses regularly taught by teaching assistants, assistant instructors, lecturers, or visiting faculty members may not be assigned to other faculty members for the purpose of computing workloads.
  
- V. For academic administration and formally assigned duties in undergraduate and graduate student advising, courses may be waived as follows:
  - A. Two or three courses may be waived for a departmental chairman as determined by the President of the institution.
  - B. No more than three courses may be waived for formal assignment as an undergraduate or graduate advisor, or as a coordinator of large multi-sectioned courses, as determined by the President of the institution.
  - C. An appropriate part of the minimum faculty workload may be waived by the President of the institution for a Special Faculty Assignment clearly related to the teaching function of the institution.
  - D. The President of the institution may waive one or two courses for new faculty members for the first academic year of employment to permit them to develop courses and establish academic programs.
  - E. For major university committees designated by the President, the President may waive one-half course for chairmanship, but not more than one course for any one individual.
  
- VI. Deans and department chairmen shall construct teaching schedules in conformance with minimum workload standards. In cases in which a faculty member's teaching load does not develop as projected, such as when a small class is cancelled, the President of the institution may assign other duties as recommended by the departmental chairman and Dean.
  
- VII. Based on experience with the use of these workload standards, each institutional head may recommend modifications to the Chancellor.
  
- VIII. In filing reports on individual compliance with these standards, the institutional head may explain why, in his judgment, particular individuals are carrying a full teaching load despite the fact that they do not meet the standards set forth above.



THE UNIVERSITY OF TEXAS AT AUSTIN  
OFFICE OF THE PRESIDENT  
AUSTIN, TEXAS 78712

*President*

November 3, 1971

Charles A. LeMaistre, M.D.  
Chancellor  
The University of Texas System

Dear Dr. LeMaistre:

Attached is a plan whereby I believe The University of Texas at Austin can conform to a system-wide four course work load without serious disruptions, if it is indeed necessary to have a system-wide standard. Any major change in this plan would undoubtedly generate serious problems for us. You will note that it:

- (1) Gives weight to graduate teaching and graduate student supervision;
- (2) Provides appropriate teaching credit for large classes;
- (3) Allows for the special problem of those professional schools where classroom contact hours are in excess of semester credit hours;
- (4) Recognizes that, in areas such as applied music instruction, teaching is traditionally by individual instruction;
- (5) Permits waiver of parts of the teaching load for academic administrators, student advisors, and coordinators; and,
- (6) Most important in a complex institution, gives the President the necessary flexibility, subject to the Chancellor's approval, to make modifications and exceptions in the institutional interest.

However, I must reiterate my position that in Texas, as in other states, there should be formal recognition that the complex national graduate

Charles A. LeMaistre, M.D.

November 3, 1971

Page 2

research university is very different from those colleges whose primary function is providing baccalaureate degree programs. Our faculty members have broader responsibilities in graduate programs, in developing new knowledge through research, and in disseminating that knowledge through such means as publications and public service. In such institutions, faculty members teach fewer organized classes but they do not work less. This fundamental difference should be reflected in a different minimum teaching load standard. My recommendation is that the minimum faculty work load at The University of Texas at Austin be three courses with appropriate course credit given for graduate teaching and graduate supervision, individual instruction, large classes, and long class contact hours, and with waiver given for academic administration and advising.

In administering minimum faculty work load standards, institutional productivity would be maximized if compliance with those standards could be measured on an academic year, rather than semester basis, and on the basis of departmental or college averages. Such procedures are particularly relevant to the coming spring semester for which the teaching schedule has been established for some time. Furthermore, departmental and college data compiled under such procedures could become bases against which yearly gains in productivity could be projected and achieved.

We do anticipate difficulties in recruiting new faculty as a consequence of the adoption of any formal faculty work load requirement. We hope, therefore, that, in the formal statements accompanying such action, recognition can be given in some form to the unique nature of the large national research university. Public support by the Regents and the Chancellor of The University of Texas at Austin would be much appreciated.

As an additional expression of my thoughts on the issue of minimum faculty work load standards, I am enclosing a statement I made at the last General Faculty meeting of The University of Texas at Austin.

Sincerely yours,

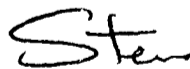

Stephen H. Spurr

SHS/gp

Enclosures

MINIMUM FACULTY WORKLOAD STANDARDS  
GENERAL ACADEMIC INSTITUTIONS  
THE UNIVERSITY OF TEXAS SYSTEM

- I. The basic faculty workload unit shall be the three-hour undergraduate course with an enrollment of at least ten students. The minimum faculty workload for the general academic institutions in The University of Texas System shall be four courses.
- II. Course credit may be given for other teaching and teaching-related activities, and courses may be waived for academic administrative assignments. All faculty members shall teach at least two organized courses, except in those departments, schools, or colleges where teaching is traditionally and appropriately by individual instruction.
- III. The calculation of faculty workloads may be made as follows:
  - A. For a faculty member who has less than a full-time appointment or who is budgeted for less than 100% of his salary from "Teaching Salaries", the minimum workload will be reduced proportionately.
  - B. Fractions of course credits may be combined to arrive at a total workload.
  - C. In the case of courses with regular scheduled classroom contact less than or more than the three hours of the standard course, credit will be given on the basis of the number of classroom contact hours met by the instructor, and counted as three regular scheduled contact hours equivalent to one course. In those cases where laboratory, discussion or review sessions are regularly scheduled in addition to the classroom contact hours for a particular course, and are met by the same instructor, not more than one course credit shall be given for these additional contact hours.

- D. In the case of large undergraduate classes, extra course credit will be given as follows:
1. Classes containing more than 100 students and less than 300 students will be counted as one and one-half courses.
  2. Classes containing 300 students or more will be counted as two courses.
- E. An organized three-hour graduate class with an enrollment of five to 59 students will be the equivalent of one and one-half courses, so that two such graduate courses will be the equivalent of three standard undergraduate courses. An organized three-hour graduate class with an enrollment of 60 or more students will count as two courses.
- F. Ten undergraduate students enrolled in individual instruction courses carrying three semester hours credit will be the equivalent of one course.
- G. Five graduate students enrolled in individual instruction courses (exclusive of thesis or dissertation courses) carrying three semester hours credit will be the equivalent of one course.
- H. For applied music instruction, 4.5 registered students shall be the equivalent of one standard course.
- I. For student-teacher supervision, 4.5 students will be the equivalent of one standard course.
- J. Where classes are conducted by organized group instruction, such as in architecture, art, and drama, 4.5 contact hours per week of such instruction will be the equivalent of one course.
- K. A faculty member engaged in graduate student supervision may receive course credit for up to but not more than two courses as follows:
1. Chairmanship of three doctoral student committees for registered students shall be the equivalent of one course (maximum three years).

2. Chairmanship of five masters student committees for registered students shall be the equivalent of one course (Maximum two years).
3. Membership in ten graduate student supervising committees for registered graduate students shall be equivalent to one course (maximum three years for doctoral students, two years for masters students).

It is expected that graduate students will be registered in appropriate thesis and dissertation courses. Supervisors may not receive credit both under this item and under individual instruction courses.

- IV. For academic administration and formally assigned duties in undergraduate and graduate student advising, courses may be waived as follows:
  - A. Two or three courses may be waived for a departmental chairman as determined by the President of the institution.
  - B. No more than three courses may be waived for formal assignment as an undergraduate or graduate advisor, or as a coordinator of large multi-sectioned courses, as determined by the President of the institution.
  - C. An appropriate part of the minimum faculty workload may be waived by the President of the institution for a Special Faculty Assignment.
  - D. The President of the institution may waive one or two courses for new faculty members for the first academic year of employment to permit them to develop courses and establish academic programs.
  - E. For major university committees designated by the President, the President may waive one-half course for chairmanship and one-quarter course for membership but not more than one course.
- V. Deans and department chairmen shall construct teaching schedules in conformance with minimum workload standards. In cases in which a faculty member's teaching load does not develop as projected, such as when a small class is cancelled, the President of the institution may assign other duties as recommended by the departmental chairman and Dean.
- VI. Subject to the Chancellor's approval, the President of the institution has the authority to adjust faculty workloads to meet the educational goals of the institution.



# The University of Texas at El Paso

Office of the President

November 5, 1971

Dr. Kenneth H. Ashworth  
Vice-Chancellor for Academic Affairs  
The University of Texas System  
601 Colorado Street  
Austin, Texas 78701

U.T. SYSTEM - ACADEMIC AFFAIRS	
REC'D NOV 8 1971	
TO _____	FOR INFO AND RETURN
TO _____	PLEASE ADVISE ME
TO _____	PLEASE HANDLE

Dear Ken:

Vice President Hatch and I have carefully considered your proposal on teaching loads and find it highly acceptable as well as definitely superior to the initial possible guide lines. We believe that it will indeed work for our faculty without undue difficulty and are grateful for the flexibility it would allow to the institutional administration.

Our Office of Institutional Studies made a trial application to representative departments and found it easy to work with; their results are listed below. We have not taken the time to analyze individual deviations, but it seems clear that Physics may be overstaffed; History and Psychology are close to the norm and there is likely a good reason for one faculty member in Curriculum and Instruction to be 1.9 points short *based on 4 courses*

<u>Department</u>	<u>Number of Faculty In Compliance</u>	<u>Number of Faculty Not in Compliance</u>
Business	17	0
Curriculum & Instruction	29	2 (-1.9, -.5)
Electrical Engineering	13	0
History	17	3 (-.6, -.3, -.3)
Physics	10	6 (-1.5, -.9, -.8, -.6, -.33, -.3)
Psychology	<u>7</u>	<u>3 (-.5, -.5, -.4)</u>
	93	14

I hope that a plan such as this will be accepted by the Board.

Cordially yours,

J. R. Smiley



THE UNIVERSITY OF TEXAS SYSTEM

*Office of the Chancellor*

601 COLORADO STREET, AUSTIN, TEXAS 78701

November 5, 1971

MEMORANDUM

TO: File (Minimum Teaching Workloads)

FROM: Kenneth H. Ashworth *KHA*

President Frank Harrison called today to inform me that he and his staff had reviewed the most recently proposed System-wide workload standards (U.T. Austin proposal). They found it not only acceptable to U.T. Arlington but "excellent" and superior to the previously proposed guidelines. I discussed with him the substantive changes to be made by the U.T. System, and he agreed that they were desirable and acceptable to him.

nn

cc: Dr. Charles A. LeMaistre





THE UNIVERSITY OF TEXAS AT DALLAS

OFFICE OF THE PRESIDENT

November 10, 1971

Dr. Kenneth Ashworth  
Vice Chancellor for Academic Affairs  
The University of Texas System  
P.O. Drawer 7969  
Austin, Texas 78712

Dear Ken:

This is in response to your memorandum of November 3 in which you inquire concerning a proposed System-wide standard for teaching loads.

After consultation with our staff here, it appears that we will be able to operate within the framework laid out in the proposed standard, with one exception. The one exception to the present standard which we would like to see included relates to the fact that new institutions must be given a certain amount of leeway during the start-up time for new courses and new programs.

Sincerely,

A handwritten signature in cursive script, appearing to read 'Bryce Jordan', written in dark ink.

Bryce Jordan  
President

BJ:dm

5. U. T. Dallas, San Antonio Medical School, Galveston Medical Branch and Public Health School: Dual Positions Pursuant to Article 6252-9a, Vernon's Texas Civil Statutes. --

It is recommended that an appropriate resolution be adopted in connection with the service of each individual on each of the state or federal boards listed on the attached. This resolution is pursuant to Article 6252-9a, Vernon's Texas Civil Statutes.

NAME	CLASSIFICATION	BOARD OR COMMISSION AND COMPENSATION
<u>The University of Texas at Dallas</u>		
Francis S. Johnson	Executive Director Center for Advanced Studies	Member - National Advisory Committee on the Oceans and Atmosphere Compensation - \$100 per day.
Royston C. Clowes, Ph.D.	Professor and Head, Department of Biology	Member - Microbial Chemistry Study Section, National Institutes of Health. Compensation - Transportation plus \$25 per diem subsistence plus \$100 per day.
Claud S. Rupert, Ph.D.	Professor, Department of Biology	Member - Advanced Science Cluster Advisory Committee for Higher Sciences at Skyline Center (Dallas Independent School District). Compensation - None

The University of Texas Medical School at San Antonio

Alexis Shelokov, M.D.	Professor and Chairman, Department of Microbiology	Member - Board of Scientific Counselors of the National Institute of Dental Research, National Institutes of Health. Compensation - \$100 per day honorarium, plus \$25 per day subsistence.
-----------------------	--	---

NAME	CLASSIFICATION	BOARD OR COMMISSION AND COMPENSATION
------	----------------	---

The University of Texas  
Medical Branch at Galveston

Willard F. Verwey, M.D.	Professor and Chairman, De- partment of Microbiology	Member - Commission on Immunization, Armed Forces Epidemio- logical Board, De- partment of the Army. Compensation - per diem only, amount not known.
----------------------------	---	---

The University of Texas  
School of Public Health at Houston

Leslie A. Chambers, Ph.D.	Professor, Department of Environmental Health	Coordinating Represen- tative for the Public Health Profession - Technical Advisory Committee to the Texas Air Control Board. Compensation - expenses only.
------------------------------	--	---

# **Buildings & Grounds Committee**

## BUILDINGS AND GROUNDS COMMITTEE

Date: December 3, 1971  
Time: Following the meeting of the Academic and Developmental Affairs Committee  
Place: Main Building, Room 212  
The University of Texas at Austin  
Austin, Texas

Page  
B & G

### U. T. SYSTEM

1. Additional Authorization of Funds to System Administration Office Building 3

### U. T. AUSTIN

2. Authorization to Grant an Easement to City of Austin for an Underground Sanitary Sewer Tunnel 3

3. Marine Science Institute - Authorization to Grant a Right-of-Way Easement to County of Nueces, Texas, Across Property Owned by the Board of Regents of U. T. System, and Appointment of a Committee to Approve Metes and Bounds 3

4. McDonald Observatory Housing Development 4

### U. T. ARLINGTON

5. Modification to Central Heating and Cooling Plant Condenser Water System and Appropriation Therefor 4

6. Approval of Preliminary Plans and Outline Specifications for Fine Arts Building and Remodeling of Theater 4

7. Approval of Easement to Texas Electric Service Company 5

### U. T. DALLAS

8. Approval of Inscription of Plaque for Lloyd V. Berkner Science-Teaching Building 5

### DALLAS MEDICAL SCHOOL

9. Authorization for a Building to House North Texas Regional Computer Center 5

	<u>Page</u> <u>B &amp; G</u>
10. Notification of Grant Award and Authorization to Proceed with Final Plans and Specifications for a Limited Part of the Remodeling of Cary Building	6
11. Authorization for Landscape-Recreation Development and Appointment of Landscape Architect	6
12. Approval of Final Plans and Specifications for Phase I of Redesign of the Air Conditioning System in the Hoblitzelle Building and Authorization to Advertise	7
<b>U. T. DALLAS, U. T. PERMIAN BASIN AND U. T. SAN ANTONIO</b>	
13. Central Energy Plants - Authorization for Design of Three Facilities, Appointment of Design Engineer, and Appropriation for Engineer's Fees and Miscellaneous Expenses	7
<b>U. T. SAN ANTONIO</b>	
14. Ratification of Award of Contract to H. B. Zachry Company for Site Work and Utility Development and Appropriation Therefor	8
<b>SAN ANTONIO MEDICAL SCHOOL</b>	
15. Authorization to Grant a Right-of-Way Easement to City of San Antonio, Texas, for Widening of Babcock Road	9
<b>GALVESTON MEDICAL BRANCH</b>	
16. Renovation of Ave Maria Hall, Appointment of Project Architect and Appropriation for Architect's Fees	9
17. Approval of Change in Scope and of Preliminary Plans and Outline Specifications for the Remodeling and Renovation of Gail Borden Building and Authorization for Additional Appropriation for Architect's Fees	9
<b>M. D. ANDERSON</b>	
18. Award of Contract for Revisions to Incinerator System and Additional Appropriation Therefor	10
<b>SYSTEM NURSING SCHOOL AND U. T. AUSTIN NURSING SCHOOL</b>	
19. Additional Appropriation	11

✓ 1. U. T. SYSTEM - ADDITIONAL AUTHORIZATION OF FUNDS TO THE SYSTEM ADMINISTRATION BUILDING.--In the process of developing final plans and specifications for the System Administration Building, additional studies have determined the long term efficiency of supplying chilled water to each of the buildings in the Claudia Taylor Johnson Complex from one single unit. The cost for providing this enlarged chiller in the mechanical room of the new building is estimated to be \$175,000.00. The self-contained existing chillers in O. Henry Hall and Claudia Taylor Johnson Hall can be relocated within the System wherever such units are in demand and will provide considerable savings in mechanical costs to building projects.

The assignment of space within the 63,000 sq. ft. in this building has been completed and an allocation of funds to cover the movable furniture and furnishings for all levels has now been estimated to be \$200,000.00.

It is, therefore, recommended by System Administration that the estimated total cost of this project be approved at \$3,575,000.00 to provide for centralized chilling plant for the Claudia Taylor Johnson Complex and for completing the interior furnishings.

✓ 2. U. T. AUSTIN - AUTHORIZATION TO GRANT AN EASEMENT TO THE CITY OF AUSTIN FOR AN UNDERGROUND SANITARY SEWER TUNNEL.--The City of Austin is constructing a major cross town sanitary sewer tunnel, a portion of said tunnel will be under premises owned by the Board of Regents of The University of Texas System.

The tunnel will be  $\pm$  75' underground and will be 35.66 feet in width in part, and 22.36 feet in width in part, across Lot 9 in Block 4 of Moore Subdivision (north of 27th Street between Speedway and San Jacinto). This easement is conditioned on the fact that said sewer will be constructed in a tunnel and that neither the surface nor improvements will be disturbed by such tunnel construction.

It is recommended by President Spurr and System Administration that this easement be granted and that the Chairman of the Board be authorized to execute an agreement with the City of Austin after the easement has been approved as to content by Deputy Chancellor Walker and as to form by a University attorney.

✓ 3. U. T. AUSTIN - MARINE SCIENCE INSTITUTE - AUTHORIZATION TO GRANT A RIGHT-OF-WAY EASEMENT TO THE COUNTY OF NUECES, TEXAS, ACROSS PROPERTY OWNED BY THE BOARD OF REGENTS OF THE UNIVERSITY OF TEXAS SYSTEM, AND THE APPOINTMENT OF A COMMITTEE TO APPROVE METES AND BOUNDS.--In the development of plans for the expansion of the Marine Science Institute, it was necessary to close the extension of Tarrant Drive across University owned land. Through negotiations with City Officials of Port Aransas and County Officials of Nueces County an alternate roadway is acceptable to both parties, and will not interfere with development plans. This new roadway will require a right-of-way easement of seventy feet in part and eighty feet in part across property owned by the University, and will be an extension of Cotter Avenue and also an easement of forty feet to connect Tarrant Drive with Cotter Avenue. The cost of constructing the new roadway is to be paid by the County of Nueces.

It is recommended by President Spurr and System Administration that easements be granted, and a committee of Mr. R. S. Kristoferson, Deputy Chancellor Walker, Mr. Frank C. Erwin, Jr., and Chairman Peace be appointed to approve metes and bounds when they have been furnished by the County of Nueces. It is further recommended that the Chairman of the Board be authorized to execute all documents when they have been approved as to content by Deputy Chancellor Walker and as to form by a University of Texas System attorney.

~~4.~~ U. T. AUSTIN - McDONALD OBSERVATORY HOUSING DEVELOPMENT.--In accordance with the action requested at the Board meeting held on October 22, 1971, the Special Committee appointed to study the need for permanent housing for staff at McDonald Observatory will present a report and recommendations at the meeting.

✓ 5. U. T. ARLINGTON - MODIFICATION TO CENTRAL HEATING AND COOLING PLANT CONDENSER WATER SYSTEM AND APPROPRIATION THEREFOR.--In accordance with authorization given by the Board at the meeting held July 30, 1971, the additional 1,000 ton absorption machine has been installed at The University of Texas at Arlington and has been in continuous operation to correct the cooling deficiency. Modifications recognized at that time as necessary to the original condenser water system were not done concurrently because of the impracticality of extended shut-down during the peak cooling season. These required modifications to the condenser cooling water system, best done during the winter, include providing a common cooling tower sump, installing larger pumps, and improving piping connections both above and below ground. The estimated total project cost for these modifications is \$45,000.00, which includes a substantial contingency for unknown underground conditions associated with the work.

It is, therefore, recommended by President Harrison and System Administration that a total appropriation of \$45,000.00 be made from Unappropriated Proceeds - U. T. Arlington Combined Fee Revenue Bonds, Series 1971, to cover these costs and miscellaneous expenses.

It is further recommended that these modifications be initiated by the U. T. Arlington Physical Plant Staff at the earliest practicable time.

✓ 6. U. T. ARLINGTON - APPROVAL OF PRELIMINARY PLANS AND OUTLINE SPECIFICATIONS FOR THE FINE ARTS BUILDING AND REMODELING OF THEATER.-- In accordance with authorization given by the Board at the meeting held on January 29, 1971, preliminary plans and outline specifications for Fine Arts Building and Remodeling of Theater at The University of Texas at Arlington have been prepared by the Associated Project Architects, Parker and Croston, Fort Worth, Texas, and Paul C. Wharton, Arlington, Texas. These preliminary plans and specifications have been approved by President Harrison and System Administration. It is recommended that they be approved by the Board with authorization to the Architects to prepare final plans and specifications to be presented to the Board for approval at a later meeting. These plans and specifications cover a building of approximately 200,000 gross square feet at an estimated total project cost of \$6,500,000.00.

It is further recommended that an additional appropriation of \$227,500.00 be made from Unallocated Proceeds of Combined Fee Revenue Bonds, Series 1971, to cover miscellaneous expenses and professional fees through the preparation of final plans and specifications.



Buildings and Grounds Item No. 9 , 12/3/71 - Dallas Medical School -  
Authorization for Building to House North Texas Regional Computer Center.

Proposed List for Appointment of Project Architect:

1. Fisher and Spillman  
Architects, Inc.  
725 Southland Center  
Dallas, Texas 75201
2. Preston M. Geren, Architect and  
Engineer and Associates  
1125 Fort Worth National Bank Building  
Fort Worth, Texas
3. Beran and Shelmire, Architects  
1900 Empire Life Building  
Dallas, Texas 75201

7. U. T. ARLINGTON - APPROVAL OF EASEMENT TO TEXAS ELECTRIC SERVICE COMPANY.--In order to supply underground electrical service to the Swift School remodeling project now in progress on the campus of The University of Texas at Arlington, it is necessary to grant an easement to Texas Electric Service Company across a portion of the Owen Medlin Survey, Abstract No. 1043, as more fully described in the easement document which will be available for examination at the Board meeting. It is recommended by Vice-President Price, President Harrison, and System Administration that approval be given by the Board for such an easement to be executed by the Chairman of the Board after approval as to content by Deputy Chancellor Walker and as to legal form by a University attorney.

8. U. T. DALLAS - APPROVAL OF INSCRIPTION ON PLAQUE FOR LLOYD V. BERKNER SCIENCE-TEACHING BUILDING.--It is recommended that the inscription as set out below be approved for the plaque to be placed on the Lloyd V. Berkner Science-Teaching Building at The University of Texas at Dallas. This inscription follows the standard pattern approved by the Board at the meeting held October 1, 1966.

LLOYD V. BERKNER SCIENCE-TEACHING BUILDING  
1971

BOARD OF REGENTS

John Peace, Chairman  
Frank N. Ikard, Vice-Chairman  
Frank C. Erwin, Jr.  
Jenkins Garrett  
Mrs. Lyndon B. Johnson  
Joe M. Kilgore  
A. G. McNeese, Jr.  
Joe T. Nelson  
Dan C. Williams

Charles A. LeMaistre, M. D., Chancellor,  
The University of Texas System  
Bryce Jordan, President, The University  
of Texas at Dallas

Harwood K. Smith and Partners,  
Project Architect  
O'Rourke Construction Company,  
Contractor

9. DALLAS MEDICAL SCHOOL - AUTHORIZATION FOR A BUILDING TO HOUSE NORTH TEXAS REGIONAL COMPUTER CENTER.--The University of Texas System components in the North Texas area have recommended the establishment of a regional computer center to serve those components (see Committee of Whole Item No. 4 ) and have further recommended that the site for the facility be located on the Dallas Medical School campus. Dean Sprague and System Administration concur in this recommendation and suggest a site near the northwest corner of the medical school campus adjacent to Medical Center Drive.

A building of approximately 10,000 square feet is required to house this facility, which will have highly specialized air conditioning and electrical requirements. Initial cost studies made by Office of Facilities Planning and Construction indicate the total project cost to be \$325,000.00.

The following recommendations are made by System Administration in regard to this project:

1. That approval be given to the site on the Dallas Medical School Campus.

2. That appointment of a project architect be made from a list to be presented at the meeting, with authorization for the preparation of final plans and specifications to be brought to the Board at a future meeting.

3. That \$18,000 be appropriated from Permanent University Fund Bond proceeds to cover the Architect's fees and miscellaneous expenses.

10. DALLAS MEDICAL SCHOOL - NOTIFICATION OF GRANT AWARD AND AUTHORIZATION TO PROCEED WITH FINAL PLANS AND SPECIFICATIONS FOR A LIMITED PART OF THE REMODELING OF CARY BUILDING.--Approval of preliminary plans and outline specifications for the Remodeling of the Cary Building at The University of Texas Southwestern Medical School at Dallas was made at the June 4, 1971, meeting of the Board; however, authorization was withheld for proceeding with the preparation of final plans and specifications pending clarification of grant funding. Notification has been received from the Department of Health, Education and Welfare that a Special Project Grant Number 3-D08-ME-00026-0352 has been approved. This grant under the Health Professions Educational Improvement Program will provide funds totalling \$300,000.00 for construction purposes during Fiscal 1972 and Fiscal 1973. This will permit a limited remodeling of approximately 6,800 square feet in the southwest quadrant of the building as a first phase of the total remodeling project at an estimated cost of \$2,100,000.00.

In connection with this remodeling, the following recommendations are made by Dean Sprague and System Administration:

1. That authorization be given to proceed with the preparation of final plans and specifications for the area of 6,800 sq. ft. at an estimated total project cost of \$370,000.00.
2. That authorization be given to the Office of Facilities Planning and Construction to advertise for bids after appropriate reviews and granting agency clearances are obtained, the bids to be presented to the Board for consideration at a later date.

11. DALLAS MEDICAL SCHOOL - AUTHORIZATION FOR LANDSCAPE-RECREATION DEVELOPMENT AND APPOINTMENT OF LANDSCAPE ARCHITECT.--In conjunction with the Phase I Program and in accordance with the approved campus development plan, studies have been made by the Office of Facilities Planning and Construction of a project for landscape development and recreational facilities at The University of Texas Southwestern Medical School at Dallas. The proposed project is outside the boundaries of present construction projects. The scope includes parking lot landscape treatment, enhancement of campus boundaries and entrances, and recreation facilities, including jogging trail, handball courts, and tennis courts.

Total project cost is initially estimated to be \$125,000.00, including construction, fees and services; project funds are allotted in Dallas Medical School accounts.

It is recommended by Dean Sprague and System Administration that authorization be given for preparation of preliminary plans and specifications and appointment of a Landscape Architect be made from a list submitted at the Board meeting. It is further recommended that an appropriation of \$2,000.00 be made from Dallas Medical School Account No. 957-205 - Landscape and Recreational Projects for professional services and miscellaneous expenses through the preliminary design phase.

*Meyers + 23*

Buildings and Grounds Item No. 11 , 12/3/71 - Dallas Medical School -  
Authorization for Landscape-Recreation Development and Appointment of  
Landscape Architect.

Proposed List for Appointment of Landscape Architect:

1. Naud Burnett Associates  
4512 Travis Street  
Dallas, Texas 75205
- ✓ 2. Richard B. Myrick Associates  
2902 Lemmon  
Dallas, Texas 75204
3. North Haven Gardens, Inc.  
7700 Northaven Road  
Dallas, Texas 75230

Buildings and Grounds Item No. 13, 12/3/71 - U. T. Dallas, U. T. Permian Basin, and U. T. San Antonio - Central Energy Plants - Authorization for Design of Three Facilities, Appointment of Design Engineer, and Appropriation for Engineer's Fees and Miscellaneous Expenses.

Proposed List for Appointment of Project Engineers:

- ✓ 1. B. Segall, Jr. - Austin
2. Leo Landauer - Dallas
3. William E. Wallis - San Antonio
4. Gaynor & Sirmen - Dallas
5. Zumwalt & Vinther - Dallas

12. DALLAS MEDICAL SCHOOL - APPROVAL OF FINAL PLANS AND SPECIFICATIONS FOR PHASE I OF REDESIGN OF THE AIR CONDITIONING SYSTEM IN THE HOBLITZELLE BUILDING AND AUTHORIZATION TO ADVERTISE.--At the September 8, 1971, meeting of the Board of Regents, the firm of Gaynor and Sirmen, Inc., Engineers, was authorized to prepare final plans and specifications for the Redesign of the Air Conditioning System in the Hoblitzelle Building at The University of Texas Southwestern Medical School at Dallas.

In order that the building remain fully occupied and that research activity be conducted without disruption, the final plans and specifications are designed for phased construction. Phase I of the plans for the redesign of the air conditioning system, at an estimated cost of \$175,000.00 has now been completed.

It is, therefore, recommended by Dean Sprague and System Administration that the Board approve these Phase I plans with authorization to the Office of Facilities Planning and Construction to advertise for bids to be brought back to the Board at a later meeting.

13. U. T. DALLAS, U. T. PERMIAN BASIN, AND U. T. SAN ANTONIO - CENTRAL ENERGY PLANTS - AUTHORIZATION FOR DESIGN OF THREE FACILITIES, APPOINTMENT OF DESIGN ENGINEER, AND APPROPRIATION FOR ENGINEER'S FEES AND MISCELLANEOUS EXPENSES.--In accordance with previous authorization given by the Board at the June 4, 1971, meeting, design criteria and specifications are in the process of being developed for the securing of bid proposals from qualified companies in the field of commercial energy to provide steam and chilled water services to the three new academic campuses, The University of Texas at Dallas, The University of Texas of the Permian Basin, and The University of Texas at San Antonio. This contemplated program proposes that each successful bidder will construct the building, install the equipment and operate the facility under a service agreement with the component institution of The University of Texas System.

Investigations and evaluations have been made by the Office of Facilities Planning and Construction of similar programs previously established at U. T. El Paso, San Antonio Medical School, Dallas Medical School, and Galveston Medical Branch.

For each of the three new campuses, general needs and detailed requirements have indicated similar design criteria and each campus has predictable expansion contemplated in the near future. It is, therefore, believed that certain economies can be effected by providing one engineering design solution for a central utility plant with specific adaptations for a different site location at other campuses.

System Administration presents the following recommendations for approval of the Board:

*B. Segall*

1. That an appointment be made for a design engineer from a list to be submitted at the meeting, with authorization for the preparation of final plans and specifications to be brought to the Board for approval at a future meeting.
2. That authorization be given to Mr. R. S. Kristoferson, Director, Office of Facilities Planning and Construction, to negotiate with the appointed engineering firm for professional services, at a rate not to exceed 6%, for the design of a central utility plant with specific site adaptations for each campus.
3. That an appropriation of \$270,000.00 for engineer's fees and miscellaneous expenses be made as an advance from Permanent University Fund Bond proceeds.

14. U. T. SAN ANTONIO - RATIFICATION OF AWARD OF CONTRACT TO H. B. ZACHRY COMPANY FOR SITE WORK AND UTILITY DEVELOPMENT AND APPROPRIATION THEREFOR.--In accordance with authorization given by the Board at the meeting held on September 8, 1971, bids were called for and were received, opened, and tabulated on October 26, 1971, for Site Work and Utility Development at The University of Texas at San Antonio as shown below:

Bidder	Base Bid	Alt. No. 1	Alt. No. 2	Alt. No. 3	Alt No. 4
Leo P. Cloud, Jr. and Son and John Yantis Co., Joint Venture, New Braunfels, Texas	\$1,375,100.00	+\$150,000	-\$ 3,000	-\$273,000	-\$10,000.00
P.S. & F. Construc- tion Company and W. Tom Pengelly, Jr., Joint Venture, San Antonio, Texas	1,350,472.75	+ 159,650	- 12,000	- 340,000	- 5,733.75
H. B. Zachry Com- pany, San Antonio, Texas	1,433,715.00	+ 54,000	- 10,000	- 290,000	- 25,000.00

Each bidder submitted with his bid a bidder's bond in the amount of 5% of the greatest amount bid.

Further in accordance with authorization given by the Board at the meeting held October 22, 1971, the Special Committee appointed, consisting of President Templeton, Mr. R. S. Kristoferson, Deputy Chancellor Walker, Regent Erwin, and Chairman Peace, awarded a contract in the amount of \$1,487,715.00 to the low bidder, H. B. Zachry Company, San Antonio, Texas, as follows:

Base Bid	\$1,433,715.00
Add Alternate No. 1 (Crush and stockpile rock from the excavation instead or remov- ing it from UTSA property)	<u>54,000.00</u>
Total Contract Award	<u>\$1,487,715.00</u>

This award is within the total estimated cost of the project in the amount of \$2,100,000.00. It is recommended that the Board ratify the action taken by the Special Committee as reported above and appropriate the sum of \$1,610,000.00 as an advance from Permanent University Fund Bond proceeds to cover this contract award, Architect's Fees thereon, and miscellaneous expenses. The advance from Permanent University Fund Bond proceeds is to be repaid from the proceeds of Tuition Revenue Bonds allocated to this project.

15. SAN ANTONIO MEDICAL SCHOOL - AUTHORIZATION TO GRANT A RIGHT-OF-WAY EASEMENT TO THE CITY OF SAN ANTONIO, TEXAS, FOR WIDENING OF BABCOCK ROAD.--The City of San Antonio proposes to widen and improve Babcock Road and is requesting a Right-of-Way easement, twenty-five (25) feet in width, a distance of 1061+ feet, from Louis Pasteur Drive to Merton Minter Blvd., which is the southern boundary of the University owned tract. There are no improvements in this area of the campus, and such widening of Babcock Road will be beneficial to the University.

It is recommended by Dean Pannill and System Administration that the easement be granted and the Chairman of the Board be authorized to execute the easement document when it has been approved by Deputy Chancellor Walker as to content and by a University of Texas System attorney as to form.

*Louis Oliver*  
16. GALVESTON MEDICAL BRANCH - RENOVATION OF AVE MARIA HALL, APPOINTMENT OF PROJECT ARCHITECT AND APPROPRIATION FOR ARCHITECT'S FEES.-- In accordance with authorization given by the Board at meetings held on September 12, 1970, and October 22, 1971, Ave Maria Hall, located at 728 Market Street, Galveston, Texas, will be acquired to provide facilities for the School of Allied Health Sciences, Family Medicine Program and offices for associated activities at The University of Texas Medical Branch at Galveston. Necessary renovation will be planned to use existing space and building characteristics, thereby keeping remodeling costs at a minimum. To expedite the determination of the scope of remodeling, it is desirable to have the Project Architect initially inspect the facility, study program needs and prepare a feasibility report outlining estimated costs. It is, therefore, recommended by Vice-President Thompson, President Blocker, and System Administration that Louis Oliver, Galveston, Texas, be appointed as Project Architect with authorization to prepare a feasibility study and cost estimate on the renovation program. This report will be brought to the Board at a later meeting for review and authorization of the estimated project cost for each project. *Fig 1*

It is further recommended that an appropriation of \$5,000.00 be made from Galveston Medical Branch Project Allocation Account to be applied to Architect's Fees and miscellaneous fees through the preliminary design stage.

17. GALVESTON MEDICAL BRANCH - APPROVAL OF CHANGE IN SCOPE AND OF PRELIMINARY PLANS AND OUTLINE SPECIFICATIONS FOR THE REMODELING AND RENOVATION OF THE GAIL BORDEN BUILDING AND AUTHORIZATION FOR ADDITIONAL APPROPRIATION FOR ARCHITECTS' FEES.--In accordance with authorization given by the Board at the meeting held on July 10, 1970, preliminary plans and outline specifications have been prepared by the Project Architect, Rapp, Tackett and Fash, Galveston, Texas, for the Remodeling and Renovation of the Gail Borden Building at The University of Texas Medical Branch at Galveston. In the initial planning phase, investigations by the Office of Facilities Planning and Construction and the Project Architect have identified increased costs in construction, mechanical systems and other areas of necessary renovation. It is, therefore, requested that the Board approve a total project cost of \$1,300,000.00 in lieu of the previously authorized amount of \$1,000,000.00. These preliminary plans and specifications have been approved by President Blocker, Vice-President Thompson, and System Administration. It is recommended that they be approved by the Board with authorization to the Architect to prepare final plans and specifications to be presented to the Board for approval at a later meeting. These plans and specifications cover remodeling of a building of approximately 66,690 gross square feet at an estimated total project cost of \$1,300,000.00.

It is further recommended that an additional appropriation of \$15,000.00 be made from Galveston Medical Branch funds to cover miscellaneous expenses and professional fees during preparation of final plans and specifications.



18. M. D. ANDERSON - AWARD OF CONTRACT TO ECOLOGY INDUSTRIES FOR REVISIONS TO INCINERATOR SYSTEM AND ADDITIONAL APPROPRIATION THEREFOR.--In accordance with the authorization given by the Board at the meeting held December 13, 1968, bids were called for and were received, opened, and tabulated on October 12, 1971, as shown below, for Revisions to the Incinerator System at The University of Texas M. D. Anderson Hospital and Tumor Institute at Houston:

Bidder	Base Bid	Additive Alternate No. 1
North American Systems, Ontario, Canada	\$184,500	\$7,500
Norman Mendelsohn and Son, Inc., Scotch Plains, New Jersey	153,000	7,000
Ecology Industries, South Plainfield, New Jersey	177,950	6,850

The specifications require the bidder to furnish all required equipment including erection and required electrical and plumbing services for a complete system. Each bidder was advised of the requirement to post a performance bond in the amount of the cost of the equipment and installation.

Apparent low bidder, Norman Mendelsohn and Son, Inc., was nonresponsive in that the bid was qualified to consider installation (erection) only on a cost-plus-10% basis. North American Systems and Ecology Industries' bids were responsive.

It is recommended by President Clark and System Administration that a contract award be made to the low responsive bidder, Ecology Industries, South Plainfield, New Jersey, as follows:

Base Bid	\$177,950.00
Plus Additive Alternate No. 1 (Furnish weather protective enclosure for mill, fan and control panel)	<u>6,850.00</u>
Total Recommended Contract Award	<u>\$184,800.00</u>

To cover this project, appropriations of \$40,000, \$60,000 and \$50,000 have been previously authorized in the dockets of December 1968, October 1970 and October 1971, respectively. In order to cover the recommended contract award and contingency expenses, it is further recommended that an additional transfer of \$37,000 from Account No. 187276 (MDAH) Construction Project No. 703-94 - Physical Plant Repairs and Equipment, be approved.

19. SYSTEM NURSING SCHOOL AND U. T. AUSTIN NURSING SCHOOL - ADDITIONAL APPROPRIATION. --On September 8, 1971, the Regents awarded a contract to J. C. Evans Construction Company, Inc. , for a building for The University of Texas Nursing School (System-wide) at Austin, The University of Texas Graduate School of Nursing at Austin and The University of Texas (Undergraduate) Nursing School at Austin in the amount of \$2,817,093.

This building is to cover approximately 99,815 gross square feet. A total appropriation of \$3,183,460 has been approved to come from the following sources:

- (a) Federal Grant - \$1,278,124
- (b) Permanent University Fund Bond proceeds - \$1,905,336

It has now been found that due to increased costs for foundation work an additional \$30,000 will be needed to complete this project. Hence, it is recommended by Dean Willman, Chancellor LeMaistre and System Administration that an additional appropriation of \$30,000 be made from Permanent University Fund Bond proceeds to the Project Allotment Account.

*Kilgore "No"*

EMERGENCY ITEMS  
BUILDINGS AND GROUNDS COMMITTEE

Date: December 3, 1971

Time: Following the meeting of the Academic and Developmental  
Affairs Committee

Place: Main Building, Room 212  
The University of Texas at Austin  
Austin, Texas

Page  
B & G

U. T. AUSTIN

✓ 20. Appointment of Committee to Award Contract for  
Addition to Research Facilities and Headquarters Building,  
Physical Plant Building, and Housing at Port Aransas  
Marine Institute 13

21. Award of Contract to Roofco, Inc., for Roof Repair  
of Applied Research Laboratory Building at Balcones Research  
Center 13

DALLAS MEDICAL SCHOOL

22. Appointment of Committee to Award Contracts for Two  
Electron Microscopes 14

20. U. T. AUSTIN - APPOINTMENT OF COMMITTEE TO AWARD CONTRACT FOR ADDITION TO RESEARCH FACILITIES AND HEADQUARTERS BUILDING, PHYSICAL PLANT BUILDING, AND HOUSING AT PORT ARANSAS MARINE INSTITUTE.-- In accordance with authorization given at the Regents' Meeting held October 22, 1971, bids were called for on the Addition to Research Facilities and Headquarters Building, Physical Plant Building, and Housing at The University of Texas Marine Science Institute at Port Aransas, to be received on November 30, 1971. During the last week, numerous telephone calls were received from the Project Architects, McCord and Lorenz, and from prospective bidders pointing out the problems of bidding on a project of this size immediately after the long Thanksgiving week-end and stating that there was a possibility of receiving fewer bids and higher bids than would be the case if the bid opening was postponed. To help insure the receipt of favorable bids from a large number of bidders, it was decided to postpone the bid opening until December 7, 1971. In order that a contract award may be made before the meeting to be held January 28, 1971, it is recommended by President Spurr and System Administration that a Committee consisting of Mr. John Thompson, President Spurr, Mr. R. S. Kristoferson, Deputy Chancellor Walker, Regent Erwin, and Chairman Peace be appointed to award a contract for this project within the estimated cost of the project, \$3,000,000.00.

21. U. T. AUSTIN - AWARD OF CONTRACT TO ROOFCO, INC., FOR ROOF REPAIR OF APPLIED RESEARCH LABORATORY BUILDING AT BALCONES RESEARCH CENTER.-- In accordance with authorization given by the Board at the meeting held October 22, 1971, bids for the Roof Repair of the Applied Research Laboratory Building at Balcones Research Center, The University of Texas at Austin, were called for and were received, opened, and tabulated on November 30, 1971, as shown below:

Bidder	Base Bid	Bidder's Bond
Air Conditioning, Inc., Austin, Texas	\$210,540.00	5%
Anken Construction Company, Inc., Austin, Texas	244,700.00	5%
Canyon Construction Company, Austin, Texas	206,000.00	5%
Roofco, Inc., Waco, Texas	143,832.00	5%

The Project Architect's final estimate of cost totalled \$142,257.00 for the rehabilitation work on this building of 111,568 gross square feet.

Detailed investigation coincident with final design for the necessary roof repair indicated that the original cost of \$75,000.00 was underestimated by the Office of Facilities Planning and Construction. An increase in the original scope of the project was necessary to concurrently accomplish (a) replacement of inadequate mechanical ventilators, (b) extensive modification of the roof overhang and fascia detail, (c) installation of new mountings for roof-top air conditioning units, and (d) additional electrical and mechanical modifications required by the roof repair. Since the project was authorized, additional Federal safety requirements have also been established for the construction industry which result in significant increase in costs.

It is recommended by President Spurr and System Administration that a contract award in the amount of \$143,832.00 be made to Roofco, Inc., Waco, Texas. In order to cover the recommended contract award, Architect's Fees thereon, and miscellaneous expenses, it is further recommended that the Board approve an appropriation of \$150,000.00 from Available University Fund.

22. DALLAS MEDICAL SCHOOL - APPOINTMENT OF COMMITTEE TO AWARD CONTRACTS FOR TWO ELECTRON MICROSCOPES.--Bids were called for to be received on November 30, 1971, on two Electron Microscopes for the Basic Science Teaching Unit under construction at The University of Texas Southwestern Medical School at Dallas. Prospective bidders have informed the Office of Facilities Planning and Construction that insufficient time was allowed for the preparation of these bids in view of the Thanksgiving holidays, and the bid opening was subsequently postponed until December 7, 1971. In order that a contract award or awards may be made before the January 28, 1971, meeting, it is recommended by Dean Sprague and System Administration that a Committee consisting of Dean Sprague, Mr. R. S. Kristoferson, Deputy Chancellor Walker, Regent Erwin, and Chairman Peace be appointed to award contracts for the two Electron Microscopes subject to approval of the award by the Federal granting agency. The funds needed to cover this contract award are available in the Allotment Account for this project.

# **Medical Affairs Committee**

MEDICAL AFFAIRS COMMITTEE

Date: December 3, 1971

Time: Following the meeting of the Buildings and Grounds Committee

Place: Main Building, Room 212  
The University of Texas at Austin  
Austin, Texas

Page  
MED

1. Dallas Medical School and System Nursing School:  
Reconsideration of Certificate Program for  
Pediatric Nurse Practitioners

1

1. Dallas Medical School and System Nursing School: Reconsideration of Certificate Program for Pediatric Nurse Practitioners. --

At the September 8th meeting of the Board, approval was given to the Dallas Medical School and the System Nursing School to establish a certificate program for Pediatric Nurse Practitioners "subject to clarification...that the program is not in violation of the Texas Medical Practice Act."

~~Subsequent to that action~~ discussions have been held between the chief administrative officers of the two institutions, the Dallas Pediatric Society, Vice-Chancellor Knisely, and legal counsel for the System and the Texas Medical Association. These discussions resulted in slight modifications to the original proposed program, including repeated emphasis that the duties of these practitioners will be under the direct supervision of a licensed physician. Legal counsel for the System and for the Texas Medical Association are now agreed that the revised proposal is not in conflict with the Texas Medical Practice Act.

System Administration recommends that the Board remove the condition on their prior approval of this certificate program, approve the modified proposal dated November 3, 1971, and authorize the submission to the Coordinating Board of this modified proposal for this certificate program.

Since copies of these academic proposals are routinely not included in the MSA, a copy of the original proposal (dated July 29, 1971) and the revised proposal (dated November 3, 1971) are on file with the Secretary to the Board of Regents.

# **Land & Investment Committee**



LAND AND INVESTMENT COMMITTEE

Date : December 3, 1971  
Time : Following the meeting of the Medical Affairs Committee  
Place : Main Building, Room 212  
U. T. Austin

PERMANENT UNIVERSITY FUND

	<u>Page</u> <u>L &amp; I</u>
INVESTMENT MATTERS:	
1. Report on Permanent University Fund Investments for the Fiscal Year Ended August 31, 1971.	3
2. Report on Clearance of Monies to Permanent University Fund and Available Fund for the Current Fiscal Year through October 31, 1971.	4
LAND MATTERS:	
3. Easements Nos. 3323 through 3340.	5
4. Amendment to Pipe Line Easement No. 3251.	7
5. Material Source Permits Nos. 394 and 395.	7
6. Sale and Easement Re Interstate Highway 10.	8
TRUST AND SPECIAL FUNDS	
GIFT, BEQUEST AND ESTATE MATTERS:	
7. U. T. El Paso - Recommendation for Acceptance of Bequest Under the Will of Miss Gladys Johnston.	9
8. Dallas Medical School - Proposed Gift Establishing Lydia K. Karcher Fund for Medical Excellence	10
REAL ESTATE MATTERS:	
9. U. T. Austin - Hogg Foundation: W. C. Hogg Memorial Fund - Request for Waiver of Surface Rights as to One-Half Mineral Interest Under Tract in Montgomery County.	10
10. U. T. Austin - Hogg Foundation: W. C. Hogg Memorial Fund - Recommendation for Renewal of Lease to Simpson Dining Car at Main and Bell, Houston.	11
11. U. T. Austin - Brackenridge Tract - Renewal of Lease to Mr. James A. Maines, DBA Boat Town of Texas.	11

12. U. T. Austin - L. D. Marie, and Edwin Gale Professorship in Judaic Studies - Recommendation to Approve Contract to Mr. Charles N. Gillette for Timber Cutting on Lots 29, 30, 33 and 34, Charles A. Felder League A-21, Hardin County, Texas. 11
13. U. T. El Paso - Frank B. Cotton Trust - Approval of Grazing Lease to Mrs. Stella C. Kelcy, Femme Sole, and Cancellation of Lease to D. E. Loveridge. 12
14. U. T. El Paso - Frank B. Cotton Trust - Recommendation for Approval of Assignment of Grazing Lease from Roy E. Herring, Jr., to Rail-X Land & Cattle, Inc. 12
15. U. T. El Paso - Josephine Clardy Fox Fund - Recommendation to Sell Lots 1 and 2, Clardy Subdivision, Number One, El Paso, to Safeway Stores, Incorporated. 12
16. U. T. El Paso - Josephine Clardy Fox Fund - Recommendation to Sell a Portion of Block 41, Clardy Fox Addition to O. J. and Oscar Benetiz. 12
17. San Antonio Medical School - Holman Cartwright Fund - Recommendation for Sale of Lots 5 and 6, Blocks 33-A, in College Acres Extension Addition, Beaumont, Texas, to E. H. Hurst. 13

OTHER MATTERS

18. Report of Securities Transactions for Permanent University Fund and for Trust and Special Funds for the Month of September 1971 13

PERMANENT UNIVERSITY FUND - INVESTMENT MATTERS.--

1. REPORT ON PERMANENT UNIVERSITY FUND INVESTMENTS FOR THE FISCAL YEAR ENDED AUGUST 31, 1971.--Under separate bound cover the Associate Deputy Chancellor for Investments, Trusts and Lands presents a report on the Permanent University Fund investments for the fiscal year ended August 31, 1971. During the fiscal year, periodic reports of investment transactions made for the Fund were submitted to the Board for approval. The present report summarizes the investment transactions for the fiscal year and indicates the status of the Fund's portfolio as of August 31, 1971.

Even though the investment climate existing throughout the past five year period has been most difficult, it is felt that worthwhile overall results have been produced. Much of the success which has been achieved may be attributed to the Amendment to the State Constitution approved by the Voters in November, 1968, which removed the mandate that not less than 50% of the Fund be invested in U. S. Government Bonds. Without the active support of the Governor, the Legislature, the Regents and friends of the University this could not have been accomplished.

The following comparison of the assets and earnings of the Permanent University Fund should be of interest:

	Fiscal Year Ended 8/31		Increase	
	1966	1971	Amount	%
Book Value	\$478,887,155.	\$594,843,538.	\$115,956,383.	24.2
Investment Income	17,098,581.	26,719,907.	9,621,326.	56.2

Of the growth in book value of \$115,956,383., realized gains on sales of securities accounted for \$15,293,913. \$26,912,641. of the funds representing the growth in book value were invested in fixed income securities, and the balance of such funds, \$89,049,221., was invested, or set aside for investment in Equities.

It is recommended by the Associate Deputy Chancellor for Investments, Trusts and Lands that the formal report be approved in order that copies thereof may be distributed to the Governor, members of the Legislature and other State Officials, as required by H.B. 1198, passed at the regular session of the 62nd Legislature.

2. REPORT ON CLEARANCE OF MONIES TO PERMANENT UNIVERSITY FUND AND AVAILABLE FUND.--The Auditor, Auditing Oil and Gas Production, reports the following with respect to monies cleared by the General Land Office to the Permanent University and Available University Fund for the current fiscal year through October 31, 1971, as follows:

<u>Permanent University Fund</u>	<u>October, 1971</u>	<u>Cumulative This Fiscal Year</u>	<u>Cumulative Preceding Fiscal Year (Averaged)</u>
Royalty			
Oil	\$ 1,103,964.83	\$ 2,227,455.08	\$ 2,660,041.14
Gas - Regular	380,808.58	482,923.02	400,154.64
- F. P. C.	81.12	768.99	4,478.44
Water	7,001.29	26,350.62	25,486.50
Salt Brine	939.73	2,461.98	2,397.60
Rental on Mineral Leases	4,457.81	73,635.08	44,816.36
Rental on Water Contracts	-0-	-0-	879.16
Rental on Brine Contracts	-0-	-0-	66.66
Amendments and Extensions of Mineral Leases	( 647.30)	( 647.30)	71,978.96
	<u>\$ 1,496,606.06</u>	<u>\$ 2,812,947.47</u>	<u>\$ 3,210,299.46</u>
Bonuses, Mineral Lease Sales (Actual)	-0-	4,769,600.00	1,407,000.00
Total - Permanent University Fund	<u>\$ 1,496,606.06</u>	<u>\$ 7,582,547.47</u>	<u>\$ 4,617,299.46</u>
 <u>Available University Fund</u>			
Rental on Easements	\$ 508.29	\$ 23,787.60	29,748.76
Interest on Easements and Royalty	214.70	304.09	157.68
Correction Fees - Easements	-0-	-0-	8.34
Transfer and Relinquishment Fees	71.81	103.11	753.72
Total - Available University Fund	<u>\$ 794.80</u>	<u>\$ 24,194.80</u>	<u>\$ 30,668.50</u>
 Total - Permanent and Available University Funds	<u>\$ 1,497,400.86</u>	<u>\$ 7,606,742.27</u>	<u>\$ 4,647,967.96</u>
 <u>Oil and Gas Development - October 31, 1971</u>			
Acreage Under Lease	593,055		
Number of Producing Acres	319,125		
Number of Producing Leases	1,415		

PERMANENT UNIVERSITY FUND - LAND MATTERS.--

3. LEASES AND EASEMENTS.--It is recommended by the Associate Deputy Chancellor for Investments, Trusts and Lands that the following applications for various leases, easements, assignments, amendments, material source permits and water contracts on University Lands be approved. All have been approved as to form and as to content by the appropriate officials.

EASEMENTS AND SURFACE LEASES

All easements and surface leases are at the standard rates; are on the University's standard forms; and payment has been received in advance, unless otherwise stated.

No.	Company	Type of Permit	County	Location (Block #)	Distance or Area	Period	Consideration
3323	Gulf Oil Corporation (Renewal of 1657)	Pipe Line	Ector	35	146 rds 2½ inch	12/1/71- 11/30/81	\$ 94.90
3324	Lo-Vaca Gathering Co.	Pipe Line	Ward	16	1,158.85 rds 6 5/8 inch	10/1/71- 9/30/81	1,506.51
3325	El Paso Natural Gas Co.	Pipe Line	Ector	35	13.30 rds 6 5/8 inch	10/1/71- 9/30/81	50.00 (Minimum)
3326	BTA Oil Producers	Pipe Line	Ward	16	111.02 rds 2 7/8 inch	9/1/71- 8/31/81	72.16
3327	Louis Crouch (Renewal of 1624)	Pipe Line	Pecos	28	741.2 rds 4 ½ inch	11/1/71- 10/31/81	481.78
3328	Northwest Production Corp.	Pipe Line	Crockett	47	130 rds 4 inch	6/1/71- 5/31/81	84.50
3329	Texaco, Inc.	Pipe Line	Andrews	5	33 rds 2 3/8 inch	11/1/71- 10/31/81	50.00 (Minimum)

Easements and Surface Leases - Continued --

No.	Company	Type of Permit	County	Location (Block#)	Distance of Area	Period	Consideration
3330	ARCO Pipe Line Company (Renewal of 1626)	Surface Lease (Pump station and tank farm site)	Crane	31	40 acres	1/1/72- 12/31/81	\$ 800.00 (Full)
3331	ARCO Pipe Line Company (Renewal of 1627)	Surface Lease (Pump station)	Reagan	9	40 acres	1/1/72 - 12/31/81	800.00 (Full)
3332	ARCO Pipe Line Company (Renewal of 1613)	Pipe Line	Crane	31	1,182.47 rds 6 inch	11/1/71- 10/31/81	1,537.21
3333	Texas Electric Service Company	Power Line	Ward	16	157.82 rds single pole	12/1/71- 11/30/81	94.69
3334	Phillips Pipe Line Company (Renewal of 1617)	Pipe Line	Andrews	11	510.8 rds 4½ inch	12/1/71- 11/30/81	332.02
3335	Phillips Petroleum Company	Pipe Line	Crane	31	201.3 rds 3½ inch	9/1/71- 8/31/81	130.85
3336	Phillips Petroleum Company (Renewal of 1629)	Pipe Line	Andrews	10, 11	201.5 rds 4½ inch	12/1/71- 11/30/81	130.98
3337	Texas Electric Service Company	Power Line	Ector	35	102.49 rds single pole	12/1/71- 11/30/81	61.49
3338	Texas Electric Service Company	Power Line	Andrews	1, 8, 9, 11, 13	539.88 rds single pole	12/1/71- 11/30/81	323.93
3339	Community Public Service Co. (Renewal of 1542)	Power Line	Pecos	28	528 rods single pole	10/1/70- 9/30/80	316.80

Easements and Surface Leases - Continued --

No.	Company	Type of Permit	County	Location (Block#)	Distance or Area	Period	Consideration
3340	Warren Petroleum Corporation (Renewal of 1635)	Pipe Line	Crane	31	816.4 rds 4½ inch	12/1/71- 11/30/81	\$ 530.66

✓ 4. AMENDMENT TO PIPE LINE EASEMENT

3251	Phillips Petroleum Company (Renewal of 1567)	Pipe Line	Andrews	1 & 11	251.1 rds various sized	4/1/71- 3/31/81	50.00*
------	---	-----------	---------	--------	----------------------------	--------------------	--------

✓ 5. MATERIAL SOURCE PERMITS

No.	Grantee	County	Location	Quantity	Consideration
394	Weatherby Engineering Company	Ward	Block 16	158 cubic yards gravel	158.00
395	South Texas Construction Company	Andrews	Block 11	66,331.77 tons caliche	4,974.88

\* This is to correct the field note description of the line after construction. The total roddage remains the same

6. SALE AND EASEMENT RE INTERSTATE HIGHWAY 10.--The State Highway Department is in the process of acquiring right of way for Interstate Highway 10 in Crockett County, and has been negotiating for sometime with respect to right of way across Blocks 29, 30 and 31, University Lands in Crockett County. This involves:

Purchase of land for right of way 1,310.087 acres

Purchase of Easement for Drainage Channels and Dykes 43.576 acres

Subject to approval of the Board of Regents, we have tentatively reached agreement with the Highway Department for a settlement on the following basis:

Sale of surface only of 1,310.087 acres at \$43.00 \$ 56,332.00

Sale of Easement on 43.576 acres at \$29.80 1,298.00  
57,630.00

Damages - Payment to cover cost of replacement of improvements to be destroyed, or which will have to be built to preserve the productive use of the various leases - (Net) 56,109.00  
\$113,739.00

In addition to the cash consideration, as set out above, the Highway Department agrees to build underpass structures at five separate locations and to permit our lessees to move livestock through them from one side of the highway to the other. Three of these structures are planned of such size that no additional expenditure is required on the part of the Highway Department. Those to be provided at Stations 59 and 151, however, were not planned to be of sufficient size for the movement of livestock. The proposed settlement includes an obligation on the part of the Highway Department to enlarge these to 10' x 10' structures at an estimated cost to the Highway Department of \$3,604 and \$3,114 respectively, or a total of \$6,718.

Mr. Billy Carr, Land Agent, and the Associate Deputy Chancellor for Investments, Trusts and Lands recommend approval of the proposed settlement, and that authority be granted to execute the necessary instruments and adjust the rentals under the various grass leases involved.

The settlement also involves a sale back to The University of Texas System of the following improvements, which will be relocated by University Lessees when it is necessary that they be moved:

	<u>Appraisal</u>	<u>Sale Price</u>
<u>W. A. Childress Lease</u>		
Pens and drenching chute	\$ 825.00	\$ 40.00
Watering facilities	1,254.00	3.00
<u>Ernest Dunlap Lease</u>		
Pens	120.00	5.00
<u>Walter Owens Lease</u>		
Pens and Water Trough	1,040.00	50.00
	<u>\$3,239.00</u>	<u>\$ 98.00</u>



TRUST AND SPECIAL FUNDS - GIFT, BEQUEST AND ESTATE MATTERS.--

7. U. T. EL PASO - RECOMMENDATION FOR ACCEPTANCE OF BEQUEST UNDER THE WILL OF MISS GLADYS JOHNSTON.--Under the terms and provisions of the Last Will and Testament of Gladys Johnston, which has been duly admitted to probate in El Paso County, Texas, the residue of her estate was bequeathed to the Board of Regents of The University of Texas System to establish a fund to be known as the Gladys Johnston Memorial Fund of The University of Texas at El Paso as a memorial to the testatrix, her mother, Theresa Kellogg Johnston, and her brothers, Harry Farnes Johnston and William Adair Johnston, all of whom are now deceased. The income from such fund is to be used for the following purposes:

1. To purchase books and library equipment for the Library of The University of Texas at El Paso.
2. To provide, when possible, for Fellowships and Scholarships to students attending The University of Texas at El Paso.
3. To assist, when possible, in providing financial assistance to lecture programs at The University of Texas at El Paso.
4. The Board of Regents may, in its sole discretion and judgment, allocate the income from such fund to the uses enumerated above; although it is my preference that the uses listed be given priority in the order in which they are listed.
5. In the event the principal of the fund established by this will ever exceeds the sum of \$30,000.00, then, any such assets over and above said sum of \$30,000.00 may be used for such purposes as may be deemed necessary for the general use and benefit of The University of Texas at El Paso.

Gladys Johnston had previously been declared a person of unsound mind in Cause No. 20963 in the County Court of El Paso, Texas, and died on September 4, 1971. The Final Account filed by Tom B. Newman, Jr., Temporary Guardian of the Estate of Gladys Johnston, NCM, indicates that the total estate amounts to approximately \$22,000.00 in cash together with certain antiques, paintings, jewelry, and other items valued at approximately \$2,800.00. The State National Bank of El Paso has qualified as Independent Executor of the Estate of Gladys Johnston, Deceased.

President Smiley joins with the Associate Deputy Chancellor for Investments, Trusts and Lands in recommending that the bequest under the Will of Gladys Johnston, Deceased, be accepted and that the necessary or desired action on behalf of the Board of Regents to settle said estate be authorized.

8. DALLAS MEDICAL SCHOOL - PROPOSED GIFT ESTABLISHING THE LYDIA K. KARCHER FUND FOR MEDICAL EXCELLENCE.--On October 21, 1971, the Office of Investments, Trusts and Lands received a trust agreement dated October 1, 1971, establishing the Lydia K. Karcher Fund for Medical Excellence at Southwestern Medical School at Dallas. The fund which is to be administered by the Board of Regents of The University of Texas System for the use and benefit of The University of Texas Southwestern Medical School at Dallas is being established by transfers as follows:

From Robert S. Strauss and Ray L. Pollock, Trustees of the Lydia K. Karcher Foundation:		
Cash	\$14,000	
1,700 shares AT&T stock @ \$42.25 (close 10/20/71)	<u>71,825</u>	\$85,825.
From Lydia K. Karcher, Individually, acting by and through her Attorney-in-fact, J. Paul Karcher 300 shares AT&T stock @ \$42.25		
		<u>12,675.</u>
		\$98,500.

The net income of the fund is to be "used annually for whatever is the most urgent need of The University of Texas Southwestern Medical School at Dallas (or its successor institution) as determined by the Dean of said Medical School or his successor as head of said School (or its successor institution) whatever his title may be in his sole and absolute discretion."

Acceptance of the above was informally approved at the Regents meeting on October 22, 1971. It is being resubmitted for formal ratification.

TRUST AND SPECIAL FUNDS - REAL ESTATE MATTERS.--

9. U.T. AUSTIN - HOGG FOUNDATION: W. C. HOGG MEMORIAL FUND - REQUEST FOR WAIVER OF SURFACE RIGHTS AS TO ONE-HALF MINERAL INTEREST UNDER TRACT IN MONTGOMERY COUNTY.--In 1943, the Board of Regents as Trustee of the Hogg Foundation sold to the Sam Houston Area Council, Boy Scouts of America, 2,358 acres in Montgomery County, which became Camp Strake, retaining one-half of the minerals with the usual rights of ingress and egress for drilling, producing and marketing said minerals. In 1966, the Boy Scouts sold a tract of 30.693 acres in the Ransom House League out of the Camp Strake property, retaining their one-half of the minerals but waiving any use of the surface. The owners of this tract, Louis B. Marks, Morton Cohn, H. M. Stearns, Jr., and J. H. Wilkenfeld, have requested that the Board of Regents waive the surface rights as to its minerals. Further information will be assembled, including the matter of cash consideration, prior to the meeting of the Board of Regents and will be presented by the Associate Deputy Chancellor for Investments, Trusts and Lands, with his recommendation.

*e. Shelton  
Her  
J. Paul Karcher*

*for shopping centers*

✓ 10. U. T. AUSTIN - HOGG FOUNDATION: W. C. HOGG MEMORIAL FUND - RECOMMENDATION FOR RENEWAL OF LEASE TO SIMPSON DINING CAR AT MAIN AND BELL, HOUSTON. --Simpson Dining Car, Inc. has operated on Hogg Foundation property at Main and Bell in Houston for over 30 years with the last extension being for two years expiring December 31, 1971, at a base rental of \$1,000.00 per month plus 6% of gross sales above \$175,000.00 annually with the Dining Car to be open twenty four hours a day. Due to the problems of securing personnel, we agreed as of June 1, 1971, to permit the lessee to close from 1:00 A.M. to 6:00 A.M. with the provision that they add \$1,000.00 per week to actual sales to determine excess rental due. This estimate of \$1,000.00 in sales for closing the five hours between 1:00 A.M. and 6:00 A.M. now appears to be excessively high but they will continue through 1971 on this basis. Simpson Dining Car, Inc. has now offered to renew the lease for two years ending December 31, 1973, at the same base rental of \$1,000.00 per month plus 6% of gross sales above \$165,000.00 annually. This offer is based on the business being closed from 1:00 A.M. to 6:00 A.M. without adding the additional \$1,000.00 per week to actual sales and does not constitute an increased rental. The lease shall be subject to cancellation by lessor on 90 days notice in event of sale or long term lease of the property.

The Associate Deputy Chancellor for Investments, Trusts and Lands recommends approval of the new lease offer and authorization for execution of the appropriate lease.

✓ 11. U. T. AUSTIN - BRACKENRIDGE TRACT - RENEWAL OF LEASE TO MR. JAMES A. MAINES, DBA BOAT TOWN OF TEXAS. --The current one year lease to Mr. James A. Maines expires December 31, 1971, and is at a rental of \$200.00 per month with a 90-day cancellation clause by lessor or lessee. Mr. Maines has offered to renew this lease for one year at a monthly rental of \$225.00 with all other conditions of the lease remaining the same. We are in the process of settling a hail storm damage insurance loss of \$955.60 and the repairs will cost \$1,177.00. Since the lease stipulates that we shall not be required to make any repairs, Mr. Maines has agreed to assume responsibility for the excess damage. The increased rental is subject to appropriate governmental authority being granted under the wage-price freeze.

The Associate Deputy Chancellor for Investments, Trusts and Lands recommends approval of the lease with authorization for execution of the appropriate instrument.

✓ 12. U. T. AUSTIN - L. D., MARIE AND EDWIN GALE PROFESSORSHIP IN JUDAIC STUDIES - RECOMMENDATION TO APPROVE CONTRACT TO MR. CHARLES N. GILLETTE FOR TIMBER CUTTING ON LOTS 29, 30, 33 AND 34, CHARLES A. FELDER LEAGUE A-21, HARDIN COUNTY, TEXAS. --The assets of the L. D., Marie and Edwin Gale Professorship in Judiac Studies include a tract in Hardin County of approximately 35 acres which is heavily wooded. Mr. Charles N. Gillette, who has been recommended by the American National Bank of Beaumont and also Mr. Gale, has agreed to handle the cutting of this timber on a selective cutting basis for 10% commission of the timber sold. He estimates the sales of this first cutting to be from \$2,500.00 to \$5,000.00. Mr. Gillette then recommends a second cutting in approximately 5 years with a final cutting 15 years from now. After the final cutting, the land, which is now carried on the books at \$1,000.00 per acre, if not previously sold, should likely be placed on the market for sale as it is not producing any current income.

The Associate Deputy Chancellor for Investments, Trusts and Lands recommends approval of this contract with authorization to execute the appropriate instrument for this first contract.

Selected  
entry

✓ 13. U. T. EL PASO - FRANK B. COTTON TRUST - APPROVAL OF GRAZING LEASE TO MRS. STELLA C. KELCY, FEMME SOLE, AND CANCELLATION OF LEASE TO D. E. LOVERIDGE.-- On May 31, 1968, the Board of Regents approved a lease to Mr. Ike Kelcy on 2,160 acres in Hudspeth County at 8¢ per acre for a five-year period from July 1, 1968, through June 30, 1973. Mr. Ike Kelcy died and his widow, Mrs. Stella C. Kelcy, sold their land and also our lease to Donald E. Loveridge. The Board of Regents approved this assignment on December 4, 1970. Mr. D. E. Loveridge defaulted on his land purchase and Mrs. Kelcy has reacquired title to her property. Mr. Loveridge also defaulted in payment of the annual rental due us on July 1, 1971, and we have mailed the appropriate notice of cancellation. Mrs. Kelcy has now agreed to re-lease this tract for a five-year period from July 1, 1971, to June 30, 1976, for 8¢ per acre and therefore we will not lose any rental.

The Associate Deputy Chancellor for Investments, Trusts and Lands recommends cancellation of the existing lease to D. E. Loveridge and approval of the new lease to Mrs. Stella C. Kelcy and authorization for execution of the appropriate instruments.

✓ 14. U. T. EL PASO - FRANK B. COTTON TRUST - RECOMMENDATION FOR APPROVAL OF ASSIGNMENT OF GRAZING LEASE FROM ROY E. HERRING, JR. TO RAIL-X LAND & CATTLE, INC.--By instrument dated July 5, 1968, the Board of Regents granted to J. A. Neal a grazing lease on 6,100.95 acres in Block 2, GC & SF, Culberson County, Texas, for a five-year term ending July 31, 1973, at 10¢ per acre. On April 17, 1970, the Board of Regents approved an assignment to Home and Business Service Corporation. On October 23, 1970, the Board of Regents approved an assignment to Roy E. Herring, Jr.

Roy E. Herring, Jr., has now transferred this lease to Rail-X Land and Cattle, Inc., and the Associate Deputy Chancellor for Investments, Trusts and Lands recommends approval of this assignment with authorization for execution of the appropriate instruments.

✓ 15. U. T. EL PASO - JOSEPHINE CLARDY FOX FUND - RECOMMENDATION TO SELL LOTS 1 AND 2, CLARDY SUBDIVISION, NUMBER ONE, EL PASO, TO SAFEWAY STORES, INCORPORATED.--This vacant parcel at the corner of Paisano and Buena Vista Drive contains approximately 19,884 square feet and was appraised in October, 1970, by Mr. William W. Browning, Jr., M.A.I., for \$35,000.00. This parcel has 203.55 frontage on the south side of Paisano and a telephone cable easement crosses the property 50 feet from the east side of the lot. Safeway Stores, Inc., has offered \$46,727.40 (\$2.35 per square foot) for this lot with a survey to determine final price and with a 6% real estate commission to James A. Keller and Rogers & Belding, Inc., by seller.

Subject to Safeway Stores, Inc., assuming a "utility frontage charge" of \$1,171.00, the Associate Deputy Chancellor for Investments, Trusts and Lands recommends approval of this offer with authorization for execution of the appropriate instruments.

✓ 16. U. T. EL PASO - JOSEPHINE CLARDY FOX FUND - RECOMMENDATION TO SELL A PORTION OF BLOCK 41, CLARDY FOX ADDITION TO O. J. AND OSCAR BENETIZ.--The vacant property at the corner of Paisano and Barcelona has approximately 53,987 square feet with 180 feet frontage on Paisano and was appraised by William W. Browning, Jr., M.A.I., in October, 1970, for \$64,171.00, which is \$1.90 per square foot for the front portion and 70¢ per square foot for the rear portion. O. J. and Oscar Benetiz have offered to pay \$82,500.00 plus assuming a "utility frontage charge" of \$1,038.00 with a down payment of \$20,625.00 and the seller carrying a mortgage of \$61,875.00 at 8<sup>1</sup>/<sub>2</sub>% interest for 15 years with monthly payments of \$609.32. Seller will pay a real estate commission of 6% to Hector

Garcia and Rogers & Belding, Inc. The final price would be determined by a survey with the price at \$2.35 per square foot for the front 120 feet depth and the rear portion of approximately 180 feet depth at 95¢ per square foot.

The Associate Deputy Chancellor for Investments, Trusts and Lands recommends approval of the sale with authorization for execution of the appropriate instruments.

✓ 17. SAN ANTONIO MEDICAL SCHOOL - HOLMAN CARTWRIGHT FUND - RECOMMENDATION FOR SALE OF LOTS 5 AND 6, BLOCK 33-A, IN COLLEGE ACRES EXTENSION ADDITION, BEAUMONT, TEXAS, TO E. H. HURST.--The Holman Cartwright Fund was created by accepting the unrestricted gift of two vacant lots at a book value of \$5,000.00 each. Mr. E. H. Hurst of Fort Worth has offered \$10,000.00 for the two lots subject to his being able to acquire 33 additional adjoining lots with a commission of 6% to be paid to Mr. W. Y. Harvey by seller. The purchaser will pay \$1,500.00 down payment with the seller accepting a mortgage for the balance of \$8,500.00, payable in 10 annual installments of \$850.00 plus 7½% interest. The proposed plans are for a hospital to be built on this property and the mortgage would probably be paid in full before the end of 10 years. Although the addition has been plotted into lots, it has not been improved with streets, utilities or drainage where our lots are located.

The Associate Deputy Chancellor for Investments, Trusts and Lands recommends approval of the offer with authorization for execution of the appropriate instruments.

OTHER MATTERS.--

18. REPORT OF SECURITIES TRANSACTIONS FOR PERMANENT UNIVERSITY FUND AND FOR TRUST AND SPECIAL FUNDS FOR THE MONTH OF SEPTEMBER 1971.--The reports of securities transactions for the Permanent University Fund and Trust and Special Funds for September 1971 were mailed to the members of the Board of Regents on November 11, 1971. The results of the mail ballots will be reported by the Secretary at the meeting of the Land and Investment Committee.

D & J - Emer,

TRUST AND SPECIAL FUNDS - REAL ESTATE MATTERS.--

19. U. T. AUSTIN - THOMAS S. MAXEY PROFESSORSHIP IN LAW - RECOMMEN-  
DATION RE SALE OF HALF INTEREST IN SURFACE OF TWO TRACTS OF LAND IN GAINES  
COUNTY, TEXAS.--In response to reinvitations for bids on the surface only of two tracts of  
land, both located in Block "G", W. T. Ry. Company Survey, Gaines County, Texas, a  
one-half interest in which is owned by the above fund (the other half being owned by the  
University of the South), bids were received by the University Land Agent at 10:00 A.M.,  
December 1, 1971, as follows:

Tract One (All of Section 82 - 647 Acres)

<u>Bidder</u>	<u>Amount</u>
Monty Williams	\$51,760.00
N. M. Saunders	51,000.00

Tract Two (E/2 Section 62 - 320 Acres)

Glen B. Payne	32,160.00
Monty Williams	25,600.00
Roy W. Wicker, Jr.	22,432.00
Charles M. Medlin	21,000.00

The Land Agent, Mr. Carr, and the Associate Deputy Chancellor for Investments,  
Trusts and Lands recommend that the bid of Monty Williams for Tract One, and that of Glen  
B. Payne for Tract Two be accepted, with the deed and any other necessary documents to be  
executed by appropriate officers.

This was sent to my office  
but not posted with  
See - State + no  
approval indicated by  
"Cal" or my agent for agenda

# **Committee of the Whole**

COMMITTEE OF THE WHOLE  
Chairman Peace, Presiding

Date: December 3, 1971

Time: Following the meeting of the Land and Investment Committee

Place: Main Building, Room 212  
The University of Texas at Austin  
Austin, Texas

Page  
C of W

I.	SPECIAL ITEMS	
A.	U. T. System	
1.	Regents' <u>Rules and Regulations</u> , Part One: Amendments to Chapter II, Section 4.1 and Section 5.3 (Selection Committees for New Appointments)	2
2.	Regents' <u>Rules and Regulations</u> , Part Two: Amendments to Chapter VI, Section 10 (Staff Benefits)	4
2a.	Regental Conference Committee with Hermann Trustees for Houston Medical School	9
3.	System-wide Boiler and Machinery Insurance	10
B.	U. T. Arlington, U. T. Dallas and Dallas Medical School	
4.	Recommendation for Establishment of North Texas Regional Computer Center	11
C.	Houston Medical School	
5.	Designation of Board of Directors of Houston Medical Foundation as Agency to Serve the Development Board Function	12
II.	RATIFICATION (AFFILIATION AGREEMENT)	
	System Nursing School	
6.	Affiliation Agreement with Southwest Texas Methodist Hospital, San Antonio, Texas, for Clinical Training for Nursing Students	12
III.	ITEM FOR THE RECORD	
A.	Galveston Medical Branch	
7.	Development Board Membership	13
B.	U. T. System	
8.	Authorization to Chairman with Respect to TSP	13
IV.	SCHEDULED MEETINGS AND EVENTS	14



## A. U. T. System

### 1. Regents' Rules and Regulations, Part One: Amendments to Chapter II, Section 4.1 and Section 5.3 (Selection Committees for New Appointments). --

Chancellor LeMaistre, upon the unanimous recommendation of the Chief Administrative Officers of all the component institutions, recommends Board of Regents' adoption of the following two amendments to the Regents' Rules and Regulations. In general these two amendments will preserve the traditional consultative and advisory role of faculty and students in the selection of institutional administrative officers with whom they must regularly interrelate and communicate, while strengthening the selection process by addition of a level heretofore rarely considered formally. This additional evaluation is achieved by expanding the involvement of management and administrative considerations representing the other constituencies which the potential nominee must serve, e.g. the Board of Regents and the System Administration. This broader base for the selection process should, appropriately, provide a better review of the candidate's opportunity for success, and also allow the candidate a more complete exposure to the several constituencies whose confidence he must maintain.

The first amendment would establish a uniform System-wide procedure for establishing selection committees for the appointment of new Chief Administrative Officers in all the component institutions. Faculty and student participation is once again defined as only advisory in this selection process. This change in procedure reaffirms the primary responsibility of the Board of Regents and the U.T. System Administration for selection of a Chief Administrative Officer who can direct all of the complex matters related to an institution of higher education. The change further emphasizes the role of the Chief Administrative Officer as a member of the System Administration to whom is delegated full authority and responsibility for the management of a component institution.

The second amendment reinforces the concept that the Board of Regents, the U.T. System Administration, and the public expects the Chief Administrative Officer of an institution of higher education to execute effectively the responsibilities of his office. He is to be held responsible for executing the duties of his office and he is given therefore the authority to appoint the key administrative officers upon whom he will depend to carry out his policies and directives. Without control over such appointments, he would be held responsible for the institution with only limited authority.

Upon the adoption of these amendments, the provisions in any institutional Handbook of Operating Procedures in conflict with them must be amended to conform to the new sections in the Rules and Regulations.

(Underscored language is to be added; bracketed, capitalized language is to be deleted.)

Amend Section 4.1 of Chapter II, Part One of the Regents' Rules and Regulations as follows:

4.1 The Chancellor shall appoint the Chief Administrative Officers of the component institutions with the approval of the Board of Regents. The Chancellor shall be assisted in making his appointment by a Selection Committee made up of the Chancellor, who serves as chairman, the Deputy Chancellor for Administration, the Vice-Chancellors for Academic Affairs and Health Affairs and two Regents and three institutional heads from the U.T. System appointed by the Chairman of the Board of Regents and such other persons as the Chairman of the Board of Regents may deem appropriate. The availability of candidates and their interest in the position will be determined by this Selection Committee.

The Chancellor will ordinarily authorize the establishment of an institutional advisory committee consisting of faculty and students at the institution to consult with the Selection Committee. This faculty-student committee may, in accordance with a schedule set by the Chancellor, suggest persons who should be considered by the Selection Committee and individual members of that Committee. The Selection Committee shall be free to seek such additional consultation with the faculty and students as it deems appropriate.

The Chief Administrative Officer of each of the component institutions serves under and reports to the Chancellor, is responsible to the Chancellor, and has access to the Board of Regents only through the Chancellor.

/THE BOARD OF REGENTS, UPON RECOMMENDATION OF THE CHANCELLOR, SHALL APPOINT THE CHIEF ADMINISTRATIVE OFFICER OF EACH OF THE COMPONENT INSTITUTIONS. THE CHIEF ADMINISTRATIVE OFFICER OF EACH OF THE COMPONENT INSTITUTIONS SERVES UNDER AND REPORTS TO THE CHANCELLOR, IS RESPONSIBLE TO THE CHANCELLOR, AND HAS ACCESS TO THE BOARD OF REGENTS ONLY THROUGH THE CHANCELLOR.<sup>7</sup>

Amend Section 5.3, Chapter II, Part One, Regents' Rules and Regulations as follows:

5.3 The Board of Regents endorses the principle of reasonable faculty and student consultation in the selection of administrative officers of the component institutions, and expects the Chancellor or Chief Administrative Officer, as he deems appropriate, to consult in the selection process with representatives of the faculty and student body. However, the Chief Administrative Officer of the institution will be held responsible for executing the duties of his office and consequently shall not be bound by nominations to key administrative positions in his office by campus selection committees in making his nominations to the Chancellor. Such advice and consultation as he may seek or be given shall not be binding upon his nominations for appointments to positions in the echelon immediately below his own position.

2. Regents' Rules and Regulations, Part Two: Amendments to Chapter VI, Section 10 (Staff Benefits). --System Administration recommends amending Chapter VI of Part Two of the Regents' Rules and Regulations by adding Section 10, which follows this explanation. The following background information indicates the need for this proposed amendment.

In 1970, Congress passed legislation which required that states cover employees of state hospitals and state institutions of higher education under the State Unemployment Compensation Acts.

In 1971, the Texas Legislature passed legislation to conform to the federal requirement, and, in addition covered all other state employees. This coverage will begin on January 1, 1972.

The State maintains an Unemployment Compensation Fund into which contributions are paid by all covered employers that are on a tax basis and from which claims are paid. Insofar as employees of The University of Texas System and other state agencies are concerned, the State will be on a reimbursable (self-insured) basis. For those employees paid from State General Revenue Funds, the state will require no contributions from the employing agencies to cover benefits paid, but will appropriate directly to pay these benefits. However, for employees paid from other than State General Revenue Funds, the Unemployment Compensation Fund must be reimbursed (through the State Comptroller) for any claims paid, and a method for funding such reimbursement must be provided.

Since all employees of The University of Texas System will be covered by the Unemployment Compensation Act effective January 1, 1972, a plan must be implemented to conform to the provisions of the Act and to provide a fund from which to pay those approved claims for former employees whose salaries were not paid from State General Revenue Funds.

The implementation and administration of an Unemployment Compensation Program is set forth in the proposed amendment. In summary, the amendment provides that the System Personnel Director, working in close cooperation with component institution officials and others concerned, will be responsible for administering the program. An essential provision of the program is the establishment of a centrally administered System Unemployment Compensation Insurance Fund with an initial System-wide assessment rate of 2.7% of the first \$4200 of each employee's annual (calendar year) salary. The rate is subject to annual review and to approval by the Board of Regents, as indicated in the plan.

The program is modeled very closely on the University's other self-insurance plan, the long-established Workmen's Compensation Insurance program. The provisions of the plan have been reviewed at length with officials of component institutions, as well as state and federal agencies. It has been approved by the Texas Employment Commission (the state agency charged with administering the acts), and by the cognizant federal agency in respect to its applicability to federal contracts and grants.

Sec. 10. Unemployment Compensation Program

10.1 The University of Texas System Unemployment Compensation Program, effective January 1, 1972, and thereafter, is administered on a system-wide basis. Under the program, certain weekly benefits are payable to former employees who were separated from employment with The University of Texas System under conditions specified in the Texas Unemployment Compensation Act and are unable to find suitable employment. Two (2) methods of funding the cost of approved claims for such former employees will be in effect, as follows:

10.11 For former employees whose salaries were paid from State General Revenue Funds, the cost of approved claims chargebacks are paid by the State Comptroller as provided in the current State General Appropriation Act. Initially, the Texas Employment Commission (TEC) pays approved claims and, quarterly, notifies the State Comptroller's Office and the appropriate University of Texas System Component Institution of the claims amounts paid, by individual. TEC bills the State Comptroller's Office, which makes payments to the Texas Employment Commission from State General Revenue Funds appropriated for this purpose. Administration of claims, periodic reporting of salaries paid, and other aspects of administering the program for employees whose salaries are paid out of State General Revenue are the same as for those whose salaries are not paid out of State General Revenue, except that the assessments provided in subsection 10.4 are not applied to salaries paid from State General Revenue Funds, or such other exceptions as are deemed by the System Personnel Director to be necessary for effective administration.

10.12 For former employees whose salaries were paid from funds other than State General Revenue, the cost of approved claims chargebacks is paid initially by the State Comptroller as specified under 10.11 above. Quarterly, or periodically as otherwise required by the State Comptroller, The University of Texas System, by check made payable to the State Comptroller, reimburses the State General Revenue Fund from The University of Texas System Unemployment Compensation Insurance Fund, a self-insurance fund described in subsection 10.4.

- 10.2 The System Personnel Director, working in close cooperation with the System Comptroller and other appropriate officials of the System and its component institutions, is responsible for:
- 10.21 Administering the Unemployment Compensation Program for all employees of The University of Texas System, with the assistance of appropriate institutional officials.
  - 10.22 Determining the University's official position regarding claims protests in questionable cases, and assisting component officials in protest hearings.
  - 10.23 Representing the institutions in all cases where claims are appealed to Appeals Tribunal or Commission Review and assisting the State Attorney General as required in representing the System with institutional participation in all cases in court actions provided for in the law.
  - 10.24 Establishing and maintaining such additional policies and procedures as are necessary for the effective administration of the program as provided under existing statutes and these Rules and Regulations, including requirements for employee separation and claims administration, informing affected personnel about the Unemployment Compensation Program, and analyzing statistical data as needed.
  - 10.25 Administering the Unemployment Compensation Insurance Fund and all policies and procedures necessary to bring about effective fund management and loss control for the Unemployment Compensation Program.
  - 10.26 Maintaining records of all claims filed and paid, all chargebacks, and other records necessary to separate approved claims information applicable to student employment and extending such record-keeping to any additional group(s) of employees for which such analysis may be deemed by the System Personnel Director to be necessary for effective administration, including records necessary to determine individual "benefit ratios" under subsection 10.61 for each of the following categories of fund sources:
    - 10.261 State General Revenue
    - 10.262 Other than State General Revenue
      - (a) Organized Research (including contract research and services)

- (b) Educational Service Agreements (including training grants)
- (c) Organized Activities Related to Educational Departments (including hospitals and clinics)
- (d) Auxiliary Enterprises
- (e) All Other

10.3 All services performed in the employ of The University of Texas System are deemed to constitute employment and are provided for under the Unemployment Compensation Program. However, benefits based on service in an instructional, research, or principal administrative capacity are not payable between two contractual periods of service, as specified in the Texas Unemployment Compensation Act.

10.4 The system-wide Unemployment Compensation Insurance Fund is established January 1, 1972, to accumulate necessary funds to pay reimbursements to the State Comptroller for claims of former employees whose salaries were not paid out of State General Revenue Funds. Sources of all salaries other than State General Revenue are charged an assessment beginning on the effective date and each month or payroll period thereafter. Checks covering these charges will be forwarded monthly to the System Personnel Director for deposit in the Unemployment Compensation Insurance Fund. Following the close of each calendar quarter, or such other reporting period as may be deemed by the System Personnel Director to be necessary for effective administration, institutional chief business officers will prepare and send to the System Personnel Office reports itemizing by employees the salaries reported to the TEC and the amounts of such salaries subject to assessment. The reported assessable salaries will be reconciled to the checks submitted monthly in payment of the assessments. The reports will also contain such other information as may be required for effective reporting. In instances in which amounts may be due the Unemployment Compensation Insurance Fund from the State Comptroller for adjustments on claims paid, assessments, or as otherwise deemed necessary by the institutional chief business officers for effective and commensurate allocation of assessments or approved claims chargebacks, the State Comptroller is requested to issue a state warrant for the amount due.

10.5 Separate and apart from all other System monies or funds, an Unemployment Compensation Fund, administered under the same custodianship as other monies administered by the University, is established and maintained in one or more regular depositories of the University, secured by collateral in accordance with state statutory requirements. The fund consists of all assessments collected, all interest earned on deposits of any monies in the fund, and all other monies received for the fund from any other source. This fund is designated as a "revolving fund" under the "University of Texas Central Services Account" provision of the current General Appropriation Act. Expenditures from the Unemployment Compensation Insurance Fund are restricted to direct costs: payments and chargebacks of approved Unemployment Compensation claims, and System administrative costs not to exceed 5% per year of the balance in the fund at the beginning of each preceding year. Investments or time deposits of such funds are in accordance with regular University policies.

10.6 The University of Texas System Unemployment Compensation Insurance Fund operates under principles and methods generally consistent with those established by the Texas Employment Compensation Act for operation of the State Unemployment Compensation Fund.

10.61 After an initial development period (as provided in subsection 10.62) assessment rates will be computed based upon principles and methods consistent with provisions in the Texas Unemployment Compensation Act for determination of "Contribution" rates. In applying these principles, "benefit ratios" will be developed for determination of basic rates which will be adjusted (decreased or increased, respectively) by one-tenth of one percent (1/10 of 1%) for each \$25,000 or fraction thereof by which the amount in the Unemployment Compensation Insurance Fund exceeds \$1,755,000 or is less than \$1,215,000. Such computation will be made at the beginning of each calendar year, and the assessment rate(s) so calculated, but in no event less than one-tenth of one percent (1/10 of 1%), will be applicable to the fiscal year beginning within that calendar year.

10.62 Compensation experience and fund balances will be developed during the period January 1, 1972, through August 31, 1976. Assessment rates during this initial development period are as follows:

- 10.621 January 1, 1972, through August 31, 1973, the assessment rate is 2.7% applied to salaries and wages up to \$4,200 per employee per calendar year.
- 10.622 September 1, 1973, through August 31, 1976, the assessment rates are subject to approval of the Board of Regents based upon determinations by System Administration after review of all available data on loss experience and levels of fund balances.
- 10.63 A single assessment rate is charged to all affected fund sources on a non-discriminatory basis throughout The University of Texas System, unless differential rates are found to be desirable as between categories of funding sources and such differential rates are approved by the Board of Regents.
- 10.7 In the event that the amount in the Unemployment Compensation Insurance Fund is fully depleted and further reimbursement payments create a deficit in the fund, at the end of any month, such deficit will be recovered by additional emergency assessments which the Component Institutions will fund by distribution of the costs to all accounts based upon the covered wages which had been charged to the accounts during the month and paid from funds other than State General Revenue.
- 10.8 The System Personnel Office will issue an annual report to include separate reporting of income and disbursements by institution, fund categories, and such other information as may be deemed necessary for effective administration.
- 7
- 2a. Regental Conference Committee with Hermann Trustees for Houston Medical School. --On April 17, 1970, an affiliation agreement between the Board of Regents of The University of Texas System and the Trustees of the Hermann Hospital Estate of Houston, Harris County, Texas, was ratified. This agreement provides for a Joint Conference Committee of Trustees and Regents composed of an equal number of representatives from the Hermann Hospital Estate and The University of Texas System with the Director of the Hospital and the Dean of the Medical School as ex officio members. This Conference Committee is to consider all matters of joint concern to Hermann Hospital and The University of Texas Medical School at Houston.

Chairman Erwin and Regent Williams were named as representatives of The University of Texas System on this committee. Vice-Chairman Josey was also named to the committee both as



a Trustee of the Hermann Hospital and as a Regent of The University of Texas System.

It is recommended by Chairman Peace that Regent McNeese be named as a representative of The University of Texas System to replace former Vice-Chairman Josey, retired. With the approval of this recommendation, the Joint Conference Committee will consist of:

U. T. Representatives

Mr. Frank C. Erwin, Jr.  
Mr. A. G. McNeese, Jr.  
Mr. Dan C. Williams

Hermann Estate Representatives

Mr. John B. Holmes  
Mr. Jack S. Josey  
Mr. Walter G. Sterling

3. System-wide Boiler and Machinery Insurance. --

The University of Texas System has for many years carried boiler and machinery insurance with the Hartford Steam Boiler and Insurance Company as the engineering, inspection and servicing company. This has been a highly satisfactory arrangement for the University and we know the engineering and inspection service of this company to be most important to our institutions since they have engineers and inspectors with National Board certificates in the areas where our institutions are located.

The institutional and public risks are not highly desired in the boiler and machinery market, however the Hartford group of insurance companies are agreeable to retaining the University account in view of their long association with The University of Texas.

Our present policy expires January 1, 1972. Manual rates are prescribed by the State Board of Insurance commissioners for this type of coverage.

It is recommended that the System Administration be authorized to continue the present coverage, except that a \$50,000.00 deductible be applicable to the gas turbine at the U. T. Austin power plant, in lieu of the present \$10,000.00 deductible.

It is further recommended that The Hartford Fire Insurance Company, or wholly owned subsidiary, be authorized to issue a three-year System-wide Boiler and Machinery policy, effective January 1, 1972, at approved manual rates providing for a fifteen percent (15%) dividend approved by the State Board of Insurance. The policy issued will be 100% reinsured with Hartford Steam Boiler Inspection and Insurance Company, and all engineering, inspection and service will be provided as heretofore by said company.

Such arrangements as outlined above insure the best available protection, inspection, and service at the lowest known costs available for coverage including power plants.

B. U. T. Arlington, U. T. Dallas and  
Dallas Medical School

4. Recommendation for Establishment of North Texas Regional  
Computer Center. --

The University of Texas Components in North Texas and System Administration have been studying for some time the feasibility and desirability of establishing a joint computer facility to service the administrative, educational and research needs of the three institutions. The Council of Presidents of these components has recommended the establishment of such a regional computer center, subject to some assistance in initial funding by an advance to be repaid within a seven year period.

For the year ending August 31, 1971, expenditures for institutional computer centers in the three North Texas institutions were in excess of \$1,100,000 of which equipment rental amounted to approximately \$500,000. All of the institutions are in need of expanded programs and enlarged computer capabilities, but U. T. Arlington and Dallas Medical School have immediate requirements that deserve attention.

Based on studies to date, it is apparent that a regional computer facility, utilizing a much larger central processing unit than those now in use at any of the three components, could provide greater computer capability to all the institutions within the range of current costs, and at less cost than this capability could be provided by individual installations. An IBM 370 Model 155 computer, similar to that authorized by the Board of Regents at the October 22, 1971 meeting, could be acquired under a special option lease purchase agreement with an initial down payment of approximately \$300,000 and six annual payments of less than the current rental costs of the individual installations.

Projections indicate that the annual operating budgets of such a central facility, including amortization on an initial advance for the down payment on the purchased equipment and start-up expenses, would average about \$1,100,000 over a six-year period. This amount would include major terminals at each of the component institutions. Annual funding would be from the operating budgets of each institution, with appropriate charges to each component, and from use by other educational institutions on a time available basis.

To provide the equipment down payment and start-up expenses, it is contemplated that an advance of between \$650,000 and \$750,000 would be needed for the establishment of this North Texas Regional Computer Center, and the initial operation during the phase-out of the existing installations. Such an advance could be made from the account "Interest on Proceeds of Permanent University Fund Bonds," and scheduled for repayment by the end of the seventh year.

A North Texas Regional Computer Center, established as outlined above, would fit in with the concept of developing other regional computer centers to better serve U. T. Component Institutions throughout the state in the most economical manner possible, and to provide mutual back-up through similar equipment, operating systems and standardized programs where feasible and desirable.

System Administration joins in the recommendations of the North Texas institutions, and requests authorization to proceed with planning and funding the North Texas Regional Computer Center as outlined above, with specific details to be reported to and approved by the Board before finally proceeding.

C. Houston Medical School

*E. Lee, Jr.*

5. Designation of the Board of Directors of the Houston Medical Foundation as the Agency to Serve the Development Board Function. --

In compliance with Part One, Chapter VII, Section 2 of the Rules and Regulations, Chancellor LeMaistre concurs in the recommendation of Vice-Chancellor Knisely, Dean Smythe and Mr. Blunk that the Board of Directors of the Houston Medical Foundation be designated as the agency to serve the development board function of The University of Texas Medical School at Houston. While this group will not utilize the nomenclature of "Development Board," it has been and will continue to serve in that capacity.

II. RATIFICATION (AFFILIATION AGREEMENT). --The following affiliation agreement is reported for ratification:

6. System Nursing School: Affiliation Agreement with Southwest Texas Methodist Hospital, San Antonio, Texas, for Clinical Training for Nursing Students. --

System Nursing School:

Chancellor LeMaistre concurs in the request of Vice-Chancellor Knisely and Dean Willman that the affiliation agreement with Southwest Texas Methodist Hospital in San Antonio be ratified and that the Chairman be authorized to execute this agreement.

This agreement conforms to the model agreement approved by the Board, and has been approved both as to form and content by appropriate administrative officials.

III. ITEM FOR THE RECORD. --Below is an item that has been approved by the Committee of the Whole and is reported for the record and for ratification:

A. Galveston Medical Branch

7. Development Board Membership. --On April 23, 1971, nominations of those individuals starred (\*) in the list below were approved for membership on The University of Texas Medical Branch at Galveston Development Board. Their acceptances have been received and the complete membership of the Galveston Medical Branch Development Board follows:

	<u>TERM EXPIRES</u>
Dr. Robert W. Kimbro, Chairman, Cleburne, Texas	1972
Mr. Carl R. Byard, Galveston, Texas	1972
Dr. H. Frank Connally, Jr., Waco, Texas	1972
Dr. McIver Furman, Corpus Christi, Texas	1972
Dr. Van Doren Goodall, Clifton, Texas	1973
Dr. Walter F. Hasskarl, Brenham, Texas	1974
*Dr. Jesse B. Heath, Madisonville, Texas	1973
Mr. Harris L. Kempner, Galveston, Texas	1974
Mr. W. L. Moody IV, Galveston, Texas	1974
Dr. C. M. Phillips, Levelland, Texas	1973
Dr. Harvey Renger, Hallettsville, Texas	1972
Dr. William D. Seybold, Houston, Texas	1974
Mr. Preston Shirley, Galveston, Texas	1973
Dr. Courtney M. Townsend, Paris, Texas	1973
*Dr. Jim M. Vaughn, Tyler, Texas	1972
Mr. John M. Winterbotham, Houston, Texas	1973
Mr. Sam P. Woodson, Jr., Fort Worth, Texas	1974

B. U. T. System

8. Authorization to Chairman with Respect to TSP. --On June 4, 1971, Chairman Peace was given specific authority to employ Preston Shirley as Counsel in the TSP matter if it were deemed advisable.

IV. SCHEDULED MEETINGS AND EVENTS. --The following meetings of the Board of Regents have been scheduled:

January 28, 1972 - in Austin  
 March 10, 1972 - in Austin

F

1971

	S	M	T	W	T	F	S
DEC.					1	2	3
	5	6	7	8	9	10	11
	12	13	14	15	16	17	18
	19	20	21	22	23	24	25
	26	27	28	29	30	31	

Fall 1971

Dec. 24-29 Christmas holidays

1972

	S	M	T	W	T	F	S
JAN.	2	3	4	5	6	7	8
	9	10	11	12	13	14	15
	16	17	18	19	20	21	22
	23	24	25	26	27	28	29
	30	31					
FEB.	6	7	8	9	10	11	12
	13	14	15	16	17	18	19
	20	21	22	23	24	25	26
	27	28	29				
MAR.	5	6	7	8	9	10	11
	12	13	14	15	16	17	18
	19	20	21	22	23	24	25
	26	27	28	29	30	31	
APR.	2	3	4	5	6	7	8
	9	10	11	12	13	14	15
	16	17	18	19	20	21	22
	23	24	25	26	27	28	29
	30						
MAY	7	8	9	10	11	12	13
	14	15	16	17	18	19	20
	21	22	23	24	25	26	27
	28	29	30	31			
JUNE	4	5	6	7	8	9	10
	11	12	13	14	15	16	17
	18	19	20	21	22	23	24
	25	26	27	28	29	30	
JULY	2	3	4	5	6	7	8
	9	10	11	12	13	14	15
	16	17	18	19	20	21	22
	23	24	25	26	27	28	29
	30	31					
AUG.	6	7	8	9	10	11	12
	13	14	15	16	17	18	19
	20	21	22	23	24	25	26
	27	28	29	30	31		
SEP.	3	4	5	6	7	8	9
	10	11	12	13	14	15	16
	17	18	19	20	21	22	23
	24	25	26	27	28	29	30
OCT.	8	9	10	11	12	13	14
	15	16	17	18	19	20	21
	22	23	24	25	26	27	28
	29	30	31				
NOV.	5	6	7	8	9	10	11
	12	13	14	15	16	17	18
	19	20	21	22	23	24	25
	26	27	28	29	30		
DEC.	3	4	5	6	7	8	9
	10	11	12	13	14	15	16
	17	18	19	20	21	22	23
	24	25	26	27	28	29	30
	31						

1972

Jan. 28 Board of Regents' meeting in Austin

Mar. 10 Board of Regents' meeting in Austin

STATEMENT BY CHANCELLOR LEMAISTRE

BOARD OF REGENTS MEETING

DECEMBER 3, 1971

Cof W-Open  
Item ①

*This was not  
used at the*

*meeting*

Mr. Chairman, the changes proposed have been under consideration since mid-summer by some of our Chief Administrative Officers. They were formally drafted and modified on September 7, 1971 by the University Council (composed of all Chief Administrative Officers of the six general academic components) and by the Health Affairs Council (composed of all Chief Administrative Officers of the health components). On that same day, I chaired the meeting of all Chief Administrative Officers at which the draft proposal was finalized and prepared for submission to the Board of Regents on October 22. The item was removed from the agenda, however, to allow further consideration, if needed, and returned to the institutional heads in early November.

The System Administration, upon the unanimous recommendation of all of the Chief Administrative Officers of all the component institutions recommends adoption of the following two amendments to the Regents' Rules and Regulations. In general these two amendments will preserve the traditional consultative and advisory role of faculty and students in the selection of institutional administrative officers with whom they must regularly interrelate and communicate, while strengthening the selection process by addition of a level heretofore rarely considered formally. This additional evaluation is achieved by expanding the involvement of management and administrative considerations representing the other constituencies which the potential nominee must serve, e.g. the Board of Regents and the System Administration. This broader base for the selection process should, appropriately, provide a better review of the candidate's opportunity for success, and also allow the candidate a more complete exposure to the several constituencies whose confidence he must maintain.

The first amendment would establish a uniform System-wide procedure for establishing selection committees for the appointment of new Chief Administrative Officers in all the component institutions. Faculty and student participation is once again defined as only advisory in this selection process. This change in procedure reaffirms the primary responsibility of the Board of Regents and the U.T. System Administration for selection of a Chief Administrative Officer who can direct all of the complex matters related to an institution of higher education. The change further emphasizes the role of the Chief Administrative Officer who can direct all of the complex matters related to an institution of higher education. The change further emphasizes the role of the Chief Administrative Officer as a member of the System Administration to whom is delegated full authority and responsibility for the management of a component institution.

The second amendment reinforces the concept that the Board of Regents, the U.T. System Administration, and the public expects the Chief Administrative Officer of an institution of higher education to execute effectively the responsibilities of his office. He is to be held responsible for executing the duties of his office and he is given therefore the authority to appoint the key administrative officers upon whom he will depend to carry out his policies and directives. Without control over such appointments, he would be held responsible for the institution with only limited authority.

Upon the adoption of these amendments, the provisions in any institutional Handbook of Operating Procedures in conflict with them must be amended to conform to the new sections in the Rules and Regulations.

(Underscored language is to be added; bracketed, capitalized language is to be deleted.)

Amend Section 4.1 of Chapter II, Part One of the Regents' Rules and Regulations as follows:

- 4.1 The Chancellor shall appoint the Chief Administrative Officers of the component institutions with the approval of the Board of Regents. The Chancellor shall be assisted in making his appointment by a Selection Committee made up of the Chancellor, who serves as chairman, the Deputy Chancellor for Administration, the Vice-Chancellors for Academic Affairs and Health Affairs and two Regents and three institutional heads from the U.T. System appointed by the Chairman of the Board of Regents and such other persons as the Chairman of the Board of Regents may deem appropriate. The availability of candidates and their interest in the position will be determined by this Selection Committee.

The Chancellor will ordinarily authorize the establishment of an institutional advisory committee consisting of faculty and students at the institution to consult with the Selection Committee. This faculty-student committee may, in accordance with a schedule set by the Chancellor, suggest persons who should be considered by the Selection Committee and individual members of that Committee. The Selection Committee shall be free to seek such additional consultation with the faculty and students as it deems appropriate.

The Chief Administrative Officer of each of the component institutions serves under and reports to the Chancellor, is responsible to the Chancellor, and has access to the Board of Regents only through the Chancellor.

/THE BOARD OF REGENTS, UPON RECOMMENDATION OF THE CHANCELLOR, SHALL APPOINT THE CHIEF ADMINISTRATIVE OFFICER OF EACH OF THE COMPONENT INSTITUTIONS. THE CHIEF ADMINISTRATIVE OFFICER OF EACH OF THE COMPONENT INSTITUTIONS SERVES UNDER AND REPORTS TO THE CHANCELLOR, IS RESPONSIBLE TO THE CHANCELLOR, AND HAS ACCESS TO THE BOARD OF REGENTS ONLY THROUGH THE CHANCELLOR.<sup>7</sup>

Amend Section 5.3, Chapter II, Part One, Regents' Rules and Regulations as follows:

- 5.3 The Board of Regents endorses the principle of reasonable faculty and student consultation in the selection of administrative officers of the component institutions, and expects the Chancellor or Chief Administrative Officer, as he deems appropriate, to consult in the selection process with representatives of the faculty and student body. However, the Chief Administrative Officer of the institution will be held responsible for executing the duties of his office and consequently shall not be bound by nominations to key administrative positions in his office by campus selection committees in making his nominations to the Chancellor. Such advice and consultation as he may seek or be given shall not be binding upon his nominations for appointments to positions in the echelon immediately below his own position.

# **Meeting of the Board**



BOARD OF REGENTS OF THE UNIVERSITY OF TEXAS SYSTEM  
GENERAL TUITION REVENUE BONDS, SERIES 1971  
IN THE AMOUNT OF \$50,000,000

SALE OF THE BONDS.--As authorized, bids were called for an received until 11:00 A.M., CST, on December 2, 1971, and then publicly opened and tabulated. A copy of the tabulation is attached.

It is recommended by the Associate Deputy Chancellor for Investments, Trusts and Lands, that the Board of Regents adopt the resolution authorizing the issuance of the bonds and that the bid of White, Weld & Co. and Associates be accepted.

DESIGNATION OF PAYING AGENCY.--Attached is a tabulation of the bids received and publicly opened and tabulated at 10:00 A.M., December 2, 1971, CST, in accordance with specifications furnished prospective bidders.

It is recommended by the Associate Deputy Chancellor for Investments, Trusts and Lands, that the bid of Republic National Bank of Dallas, to serve as paying agent for this issue be accepted. The bank will charge -0-¢ per coupon and Three Dollars and Fifty Cents (\$3.50) per bond paid. The New York Co-Paying agent is First National City Bank in New York.

AWARD OF CONTRACT FOR PRINTING THE BONDS.--Attached is a tabulation of the bids received and publicly opened and tabulated at 10:00 A.M., December 2, 1971, CST, in accordance with specifications furnished prospective bidders.

It is recommended by the Associate Deputy Chancellor for Investments, Trusts and Lands that the bid of Steck Werlick Company, The Steck Division, Austin, be accepted for printing the bonds with lithographed borders, as set out in the specifications for the sum of \$3,573.00, there being seven interest rates.

TABULATION OF BIDS  
 \$50,000,000  
 BOARD OF REGENTS OF THE UNIVERSITY OF TEXAS SYSTEM  
 GENERAL TUITION REVENUE BONDS, SERIES 1971  
 Bids Opened Thursday, December 2, 1971

ACCOUNT	COUPONS	INTEREST COST	EFFECTIVE RATE
John Nuveen Company & Associates	19 72 to 87 6.00	Gross: \$52,668,420.00	5.4940
	88 - 5.40	Less	
	89 93 5.50	Prem: 2,852.70	
	94 97 5.60	Net: \$52,665,567.30	
	98 2000 5.70		
	2001 - 5.00		
	2002 - 4.50		
Halsey, Stuart & Co, Inc. Phelps, Fenn & Co. Lehman Brothers Eastment Dillon, Union Securities & Co and Associates	19 72 84 6.50	Gross: \$53,116,942.50	5.54
	85 87 5.20	Less	
	88 89 5.40	Prem: 11,000.00	
	90 92 5.50	Net: \$53,105,942.50	
	93 97 5.60		
	98 2000 5.70		
	2001 2002 5.00		
White, Weld & Company and Associates <i>at 3</i> <i>Mary &amp; Emery &amp; Smith</i>	19 72 82 6.50	Gross: \$52,376,878.75	5.4635
	83 - 5.80	Less	
	84 89 5.25	Prem: 4,118.35	
	90 92 5.40	Net: \$52,372,760.40	
	93 94 5.50		
	95 2000 5.60		
	2001 2002 5.00		
First National City Bank Morgan Guaranty Trust Co. of New York Salomon Brothers First National Bank of Dallas (Joint Managers)	19 72 84 6.50	Gross: \$52,407,821.00	5.4663
	85 - 5.60	Less	
	86 87 5.20	Prem: 7,500.00	
	88 89 5.25	Net: \$52,400,321.00	
	90 2000 5.50		
	2001 2002 5.00		
	19	Gross: \$	
		Less	
		Prem:	
		Net: \$	
	19	Gross: \$	
		Less	
		Prem:	
		Net: \$	
	19	Gross: \$	
		Less	
		Prem:	
		Net: \$	

BIDS FOR PAYING AGENCY

\$50,000,000

BOARD OF REGENTS OF THE UNIVERSITY OF TEXAS SYSTEM  
GENERAL TUITION REVENUE BONDS, SERIES 1971

Tabulation of Bids Received  
December 2, 1971 - 10:00 a.m., CST

Bidder	New York Co-Paying Agent	Per Coupon Paid	Per Bond Paid
Exchange Bank and Trust Co. P. O. Box 35207 Dallas, Texas 75235	Irving Bank and Trust Co.	5¢	\$5.00
First National Bank in Dallas P. O. Box 6031 Dallas, Texas 75222	Manufacturers Hanover Trust Company	10¢	\$1.25
Republic National Bank Dallas P. O. Box 5961 Dallas, Texas 75222	First National City Bank	0¢	\$3.50
The Texas Bank & Trust Co. One Main Place Dallas, Texas 75250	Chase Manhattan Bank	10¢	\$1.25
El Paso National Bank Drawer 140 El Paso, Texas 79999	Bankers Trust Company	15¢	\$1.05
The First National Bank of Fort Worth P. O. Box 2260 Fort Worth, Texas 76101	Manufacturers Hanover Trust Company	7½¢	\$ .90
Bank of the Southwest N.A. P. O. Box 2629 Houston, Texas 77001	Bankers Trust Company	10¢	\$1.00
Texas Commerce Bank P. O. Box 2558 Houston, Texas 77001	Bankers Trust Company	12¢	\$1.65
The Fort Worth National Bank P. O. Box 2050 Fort Worth, Texas 76101	First National City Bank	10¢	\$1.25



I would like to remind the Regents that this afternoon at  
at the Thompson Conference Center  
2:30 the institutional heads of our new general academic  
schools will outline for the program development committee  
of the Coordinating Board plans for those new schools.  
This is an information discussion only and will be the  
same material we heard at our October 22 meeting.

AGENDA  
MEETING OF THE BOARD OF REGENTS  
OF  
THE UNIVERSITY OF TEXAS SYSTEM

Chairman Peace, Presiding

Date: December 2, 1971  
Time: 12:00 noon  
Place: Main Building, Room 212  
The University of Texas  
at Austin  
Austin, Texas

A. CALL TO ORDER

B. SPECIAL ORDER

U. T. SYSTEM: (1) RESOLUTION AUTHORIZING ISSUANCE AND AWARDED SALE OF BOARD OF REGENTS OF THE UNIVERSITY OF TEXAS SYSTEM GENERAL TUITION REVENUE BONDS, SERIES 1971, \$50,000,000 (2) DESIGNATION OF PAYING AGENTS, AND (3) AWARD OF CONTRACT FOR PRINTING BONDS. --Pursuant to authorization by the Board of Regents at its meeting on October 22, 1971, bids for Board of Regents of The University of Texas System General Tuition Revenue Bonds, Series 1971, in the amount of \$50,000,000 will be considered by the Board of Regents at 12:00 noon CST on December 2, 1971, in the Main Building, Room 212. The proposed resolution authorizing issuance of the bonds and awarding the sale thereon is set out on Pages B of R 2 - 14 .

At the meeting, Associate Deputy Chancellor Shelton will present recommendations for the sale of the bonds, for the designation of the paying agents, and for the award of a contract for printing the bonds. All recommendations will be based upon the bids that have been received in each case.

Action Requested

1. Adoption of the Resolution authorizing issuance and sale of bonds and fixing rates prepared by bond counsel and set out on Pages B of R 2 through B of R 14 .
2. Designation of paying agent and co-paying agent.
3. Award of contract for printing bonds.

RESOLUTION AUTHORIZING THE ISSUANCE OF BOARD OF REGENTS  
OF THE UNIVERSITY OF TEXAS SYSTEM GENERAL TUITION REVENUE  
BONDS, SERIES 1971, \$50,000,000

WHEREAS, the Board of Regents of The University of Texas System is authorized to issue the bonds hereinafter authorized pursuant to Chapter 55, Texas Education Code.

THEREFORE, BE IT RESOLVED BY THE BOARD OF REGENTS OF THE UNIVERSITY OF TEXAS SYSTEM:

Section 1. That said Board's negotiable, serial, coupon bonds to be designated "BOARD OF REGENTS OF THE UNIVERSITY OF TEXAS SYSTEM GENERAL TUITION REVENUE BONDS, SERIES 1971," are hereby authorized to be issued, sold, and delivered in the principal amount of \$50,000,000, FOR THE PURPOSE OF PROVIDING FUNDS TO ACQUIRE, PURCHASE, CONSTRUCT, IMPROVE, ENLARGE, AND/OR EQUIP PROPERTY, BUILDINGS, STRUCTURES, AND FACILITIES FOR THE UNIVERSITY OF TEXAS AT DALLAS, THE UNIVERSITY OF TEXAS OF THE PERMIAN BASIN, THE UNIVERSITY OF TEXAS AT SAN ANTONIO, THE UNIVERSITY OF TEXAS MEDICAL SCHOOL AT HOUSTON, THE UNIVERSITY OF TEXAS DENTAL SCHOOL AT SAN ANTONIO, THE UNIVERSITY OF TEXAS (UNDERGRADUATE) NURSING SCHOOL AT EL PASO, AND THE UNIVERSITY OF TEXAS (CLINICAL) NURSING SCHOOL AT SAN ANTONIO; PROVIDED THAT THE BOARD MAY ALLOCATE ALL OR ANY PART OF SUCH FUNDS TO ANY ONE OR MORE OF SUCH INSTITUTIONS IN ITS DISCRETION AND IN ACCORDANCE WITH LAW.

Section 2. That said bonds shall be dated OCTOBER 1, 1971, shall be numbered consecutively from 1 THROUGH 10,000, shall be in the denomination of \$5,000 EACH, and shall mature and become due and payable serially on APRIL 1 in each of the years, and in the amounts, respectively, as set forth in the following schedule:

<u>YEARS</u>	<u>AMOUNTS</u>	<u>YEARS</u>	<u>AMOUNTS</u>
1972	\$1,800,000	1988	\$1,485,000
1973	610,000	1989	1,570,000
1974	705,000	1990	1,655,000
1975	740,000	1991	1,745,000
1976	785,000	1992	1,840,000
1977	825,000	1993	1,945,000
1978	870,000	1994	2,050,000
1979	920,000	1995	2,165,000
1980	970,000	1996	2,280,000
1981	1,020,000	1997	2,410,000
1982	1,080,000	1998	2,540,000
1983	1,140,000	1999	2,680,000
1984	1,200,000	2000	2,830,000
1985	1,265,000	2001	2,985,000
1986	1,335,000	2002	3,145,000
1987	1,410,000		

Said Bonds may be redeemed prior to their scheduled maturities, at the option of said Board, on the dates stated, and in the manner provided, in the FORM OF BOND set forth in this Resolution.

Section 3. That said bonds scheduled to mature during the years, respectively, set forth below shall bear interest at the following rates per annum:

maturities	1972	through	____,	____%
maturities	_____	through	____,	____%
maturities	_____	through	____,	____%
maturities	_____	through	____,	____%
maturities	_____	through	____,	____%
maturities	_____	through	____,	____%
maturities	_____	through	____,	____%
maturities	_____	through	____,	____%

Said interest shall be evidenced by interest coupons which shall appertain to said bonds, and which shall be payable on the dates stated in the FORM OF BOND set forth in this Resolution.

Section 4. That said bonds, and the interest coupons appertaining thereto, shall be payable, shall have the characteristics, and shall be signed and executed (and said Bonds shall be sealed), all as provided, and in the manner indicated, in the FORM OF BOND set forth in this Resolution.

Section 5. That the form of said bonds, including the form of Registration Certificate of the Comptroller of Public Accounts of the State of Texas to be printed and endorsed on each of said bonds, and the form of the aforesaid interest coupons which shall appertain and be attached initially to each of said bonds, shall be, respectively, substantially as follows:

FORM OF BOND:

NO. \_\_\_\_\_

\$5,000

UNITED STATES OF AMERICA  
STATE OF TEXAS  
BOARD OF REGENTS OF THE UNIVERSITY OF TEXAS SYSTEM  
GENERAL TUITION REVENUE BOND  
SERIES 1971

ON APRIL 1, \_\_\_\_\_, the BOARD OF REGENTS OF THE UNIVERSITY OF TEXAS SYSTEM promises to pay to bearer the principal amount of

FIVE THOUSAND DOLLARS

and to pay interest thereon, from the date hereof, at the rate of \_\_\_\_\_ % per annum, evidenced by interest coupons payable APRIL 1, 1972, and semi-annually thereafter on each OCTOBER 1 and APRIL 1 while this bond is outstanding.

THE PRINCIPAL of this bond and the interest coupons appertaining hereto shall be payable to bearer, in lawful money of the United States of America, without exchange or collection charges to the bearer, upon presentation and surrender of this bond or proper interest coupon, at the following, which shall constitute and be defined as the "Paying Agent" for this Series of Bonds:

THIS BOND is one of a Series of negotiable, serial, coupon bonds, dated OCTOBER 1, 1971, issued in the principal amount of \$50,000,000, FOR THE PURPOSE OF PROVIDING FUNDS TO ACQUIRE, PURCHASE, CONSTRUCT, IMPROVE, ENLARGE, AND/OR EQUIP PROPERTY, BUILDINGS, STRUCTURES, AND FACILITIES FOR THE UNIVERSITY OF TEXAS AT DALLAS, THE UNIVERSITY OF TEXAS OF THE PERMIAN BASIN, THE UNIVERSITY OF TEXAS AT SAN ANTONIO, THE UNIVERSITY OF TEXAS MEDICAL SCHOOL AT HOUSTON, THE UNIVERSITY OF TEXAS DENTAL SCHOOL AT SAN ANTONIO, THE UNIVERSITY OF TEXAS (UNDERGRADUATE) NURSING SCHOOL AT EL PASO, AND THE UNIVERSITY OF TEXAS (CLINICAL) NURSING SCHOOL AT SAN ANTONIO; PROVIDED THAT THE BOARD MAY ALLOCATE ALL OR ANY PART OF SUCH FUNDS TO ANY ONE OR MORE OF SUCH INSTITUTIONS IN ITS DISCRETION AND IN ACCORDANCE WITH LAW.

ON APRIL 1, 1982, OR ON ANY INTEREST PAYMENT DATE THEREAFTER, the outstanding bonds of this Series may be redeemed



prior to their scheduled maturities, at the option of said Board, IN WHOLE, OR IN PART, for the principal amount thereof and accrued interest thereon to the date fixed for redemption, plus a premium on the principal amount of each such bond as follows:

- 3% if redeemed April 1, 1982 through October 1, 1985
- 2% if redeemed April 1, 1986 through October 1, 1988
- 1% if redeemed April 1, 1989 through October 1, 1991
- 0% if redeemed April 1, 1992 or thereafter.

At least thirty days prior to the date fixed for any such redemption said Board shall cause a written notice of such redemption to be published at least once in a financial publication published in the City of New York, New York, or in the City of Austin, Texas. By the date fixed for any such redemption due provision shall be made with the "Paying Agent" for the payment of the required redemption price. If such written notice of redemption is published and if due provision for such payment is made, all as provided above, the bonds which are to be so redeemed thereby automatically shall be redeemed prior to their scheduled maturities, and they shall not bear interest after the date fixed for redemption, and they shall not be regarded as being outstanding except for the purpose of being paid by the "Paying Agent" with the funds so provided for such payment.

IT IS HEREBY certified, recited, and covenanted that this bond has been duly and validly issued and delivered; that all acts, conditions, and things required or proper to be performed, exist, and be done precedent to or in the issuance and delivery of this bond have been performed, existed, and been done in accordance with law; and that the interest on and principal of this bond and the Series of which it is a part, are secured by and payable from an irrevocable first lien on and pledge of specified Pledged General Tuition imposed on students enrolled at each and every institution, branch, and school now or hereafter operated by or under the jurisdiction of said Board, and a student Library Use Fee at each New System Institution of said Board, and certain Federal interest grants, and other revenues, collectively defined as "Pledged Revenues" and further described and defined in the Resolution authorizing this Series of bonds.

SAID BOARD has reserved the right, subject to the restrictions stated in said Resolution authorizing this Series of bonds, to issue additional parity revenue bonds which also may be secured by and made payable from an irrevocable first lien on and pledge of the aforesaid Pledged Revenues.

THE HOLDER HEREOF shall never have the right to demand payment of this obligation out of any funds raised or to be raised by taxation.

IN WITNESS WHEREOF, this bond and the interest coupons appertaining hereto have been signed with the facsimile signature of the Chairman of said Board and countersigned with the facsimile signature of the Secretary of said Board, and the official seal of said Board has been duly impressed, or placed in facsimile, on this bond.

XXXXXXXXX  
\_\_\_\_\_  
Secretary, Board of Regents,  
The University of Texas System

XXXXXXXXX  
\_\_\_\_\_  
Chairman, Board of Regents,  
The University of Texas System.

FORM OF REGISTRATION CERTIFICATE:

COMPTROLLER'S REGISTRATION CERTIFICATE: REGISTER NO.

I hereby certify that this bond has been examined, certified as to validity, and approved by the Attorney General of the State of Texas, and that this bond has been registered by the Comptroller of Public Accounts of the State of Texas.

Witness my signature and seal this

XXXXXXXXX  
Comptroller of Public Accounts of  
the State of Texas.

FORM OF INTEREST COUPON:

NO. \_\_\_\_\_ \$ \_\_\_\_\_

ON \_\_\_\_\_ 1, \_\_\_\_\_

THE BOARD OF REGENTS OF THE UNIVERSITY OF TEXAS SYSTEM, promises to pay to bearer the amount shown on this interest coupon, in lawful money of the United States of America, without exchange or collection charges to the bearer, unless due provision has been made for the redemption prior to maturity of the bond to which this interest coupon appertains, upon presentation and surrender of this interest coupon, at the

said amount being interest due that day on the bond, bearing the number hereinafter designated, of that issue of BOARD OF REGENTS OF THE UNIVERSITY OF TEXAS SYSTEM GENERAL TUITION REVENUE BONDS, SERIES 1971, DATED OCTOBER 1, 1971. The holder hereof shall never have the right to demand payment of this obligation out of any funds raised or to be raised by taxation. Bond No. \_\_\_\_\_.

XXXXXXXXX  
Secretary, Board of Regents      Chairman, Board of Regents

Section 6. That as used in this Resolution the following terms shall have the meanings set forth below, unless the text hereof specifically indicates otherwise:

The term "Board" shall mean the Board of Regents of The University of Texas System.

The term "Bonds" shall mean the Board of Regents of The University of Texas System General Tuition Revenue Bonds, Series 1971, authorized by this Resolution.

The term "Additional Bonds" shall mean the additional parity revenue bonds permitted to be authorized in this Resolution.

The term "Established System Institution" shall mean and include each of the following existing and operating institutions, respectively:

- The University of Texas at Austin
- The University of Texas at Arlington
- The University of Texas El Paso
- The University of Texas M. D. Anderson Hospital and Tumor Institute at Houston
- The University of Texas Graduate School of Biomedical Sciences at Houston

The University of Texas School of Public Health  
at Houston  
The University of Texas Dental Branch at Houston  
The University of Texas Medical Branch at Galveston  
The University of Texas Southwestern Medical  
School at Dallas  
The University of Texas Medical School at San Antonio  
The University of Texas Nursing School (System Wide),  
excepting the Nursing Schools at El Paso and  
San Antonio.

The term "New System Institution" shall mean and include each of the following institutions, respectively, to be operated by and under the jurisdiction of the Board, and which were newly created by various Acts of the 61st Legislature, Regular Session, 1969:

The University of Texas at Dallas  
The University of Texas of the Permian Basin  
The University of Texas at San Antonio  
The University of Texas Medical School at Houston  
The University of Texas Dental School at San Antonio  
The University of Texas (Undergraduate) Nursing  
School at El Paso  
The University of Texas (Clinical) Nursing School  
at San Antonio;

except and provided that although the Board intends to use its best efforts to acquire, purchase, construct, improve, enlarge, and/or equip buildings, structures, and facilities for the foregoing institutions as soon as practicable and to the extent permitted by law, in order to establish and commence full operation of each of said institutions as a part of The University of Texas System, the Board does not warrant or represent any particular date for commencing or completing any work at any such institution, and it is agreed and shall be understood that each such institution shall become and constitute a New System Institution, and the lien on the Pledged Revenues at any such institution shall be effective, only upon the actual enrollment of students on a regular basis and the commencement of regular operation of such institution, if and when such event occurs.

The term "each and every institution, branch, and school now or hereafter operated by or under the jurisdiction of the Board" shall mean and include all of the following:

- (a) each Established System Institution, and
- (b) each New System Institution,

together with any other institution, branch, or school now or hereafter operated by or placed under the jurisdiction of the Board pursuant to law (all collectively known as The University of Texas System).

The term "Pledged General Tuition" shall mean all of the aggregate amount of student tuition charges now or hereafter required or authorized by law to be imposed on students enrolled at each and every institution, branch, and school, now or hereafter operated by or under the jurisdiction of the Board, but specifically excluding and excepting (1) the amount of tuition scholarships now provided for by law, and (2) the following amount of such student tuition charges at each and every such institution, branch, and school which previously has been or

hereafter may be pledged to the payment of other bonds (excepting the Bonds and Additional Bonds) issued by the Board:

- (a) \$5.00 per regular semester and summer session for each student enrolled for 12 or more Semester Credit Hours; and
- (b) \$0.42 per Semester Credit Hour per regular semester and summer session for each student enrolled for less than 12 Semester Credit Hours;

and Section 55.17 (f) (2) of the Texas Education Code provides, and it is hereby covenanted, that the aggregate amount of student tuition charges which are now required or authorized by law to be imposed, and which are pledged to the payment of the Bonds and any Additional Bonds by this Resolution, shall never be reduced or abrogated while such obligations are outstanding; it being further covenanted that the aggregate amount of student tuition charges now required or authorized by law to be imposed on students enrolled at each and every institution, branch, and school operated by or under the jurisdiction of the Board are set forth in Chapter 54 of the Texas Education Code, as amended and modified by Chapters 511 and 755, Acts of the 62nd Legislature, Regular Session, 1971, to which Chapters reference is hereby made for all purposes.

The term "System Tuition" shall mean the aggregate amount of all student tuition charges actually received by The University of Texas System during any University of Texas System fiscal year, or during any twelve consecutive calendar month period, after deducting from such aggregate amount (1) the amount of tuition scholarships provided by law, and (2) the amount of such student tuition charges which has been pledged to the payment of other bonds (excepting the Bonds and Additional Bonds) issued by the Board.

The term "Library Use Fee" shall mean the gross collections of a special fee to be fixed, charged, and collected from all students (excepting those exempt by the aforesaid Chapter 755, Acts of the 62nd Legislature) regularly enrolled at each New System Institution, respectively, for the use and availability of all library facilities at each such New System Institution, respectively, in the manner and to the extent provided in this Resolution.

The term "Pledged Revenues" shall mean collectively (a) the Pledged General Tuition, (b) the Library Use Fee, (c) all debt service subsidy and interest grants received from the United States Government in connection with the Bonds and Additional Bonds, and (d) any additional revenues, income, receipts, or other resources, including, without limitation, any grants, donations, or income received or to be received from the United States Government, or any other public or private source, whether pursuant to an agreement or otherwise, which hereafter may be pledged to the payment of the Bonds or the Additional Bonds.

Section 7. (a) That the Board covenants and agrees to fix, levy, charge, and collect a uniform Library Use Fee from all students (excepting those exempt by the aforesaid Chapter 755, Acts of the 62nd Legislature) regularly enrolled in each New System Institution, respectively, at each regular fall and spring semester and at each term of each summer session, for the use and availability of all library facilities at each such New System Institution, respectively, in such amounts, without any limitation what-

soever, as will be at least sufficient at all times to provide, together with other Pledged Revenues, the money for making all deposits required to be made to the credit of the Interest and Sinking Fund and the Reserve Fund in connection with the Bonds and any Additional Bonds.

(b) That the Library Use Fee shall be fixed, levied, charged, and collected when and as required by this Section; and the Library Use Fee shall be increased if and when required by this Section, and may be decreased or abrogated, so long as all Pledged Revenues are sufficient to provide the money for making all deposits required to be made to the credit of the Interest and Sinking Fund and Reserve Fund in connection with the Bonds and any Additional Bonds. All changes in such Library Use Fee shall be made by resolution of the Board, but such procedure shall not constitute or be regarded as an amendment of this Resolution, but merely the carrying out of the provisions hereof.

Section 8. That the Bonds and any Additional Bonds, and the interest thereon, are and shall be secured by and payable from an irrevocable first lien on and pledge of the Pledged Revenues, and the Pledged Revenues are further pledged to the establishment and maintenance of the Interest and Sinking Fund and the Reserve Fund as provided in this Resolution.

Section 9. That there is hereby created and there shall be established on the books of the Board a separate account or accounts which individually or collectively shall be known as the "Revenue Fund". All collections of Pledged Revenues shall be credited to the Revenue Fund immediately upon receipt.

Section 10. That to pay the principal of and interest on all outstanding Bonds and any Additional Bonds, as the same come due, there is hereby created and there shall be established at an official depository of the Board (which must be a member of the Federal Deposit Insurance Corporation) a separate fund to be entitled the "General Tuition Revenue Bonds Interest and Sinking Fund" (herein called the "Interest and Sinking Fund").

Section 11. That there is hereby created and there shall be established at an official depository of the Board (which must be a member of the Federal Deposit Insurance Corporation) a separate fund to be entitled the "General Tuition Revenue Bonds Reserve Fund" (herein called the "Reserve Fund"). The Reserve Fund shall be used finally in retiring the last of the outstanding Bonds and Additional Bonds, or for paying principal of and interest on any outstanding Bonds and Additional Bonds, when and to the extent the amount in the Interest and Sinking Fund is insufficient for such purpose.

Section 12. (a) That money in any Fund established pursuant to this Resolution may, at the option of the Board, be placed in time deposits or invested in direct obligations of, or obligations the principal of and interest on which are guaranteed by, the United States of America, and evidences of indebtedness of the Federal Land Banks, Federal Intermediate Credit Banks, Banks for Cooperatives, Federal Home Loan Banks, or Federal National Mortgage Association; provided that all such deposits and investments shall be made in such manner that the money required to be expended from any Fund will be available at the proper time or times. Such investments shall be valued in terms of current market value as of the last day of February and August of each year. Interest and income derived from such deposits and investments shall be credited to the Fund from which the deposit or investment was made. Such investments shall be sold

promptly when necessary to prevent any default in connection with the Bonds or Additional Bonds.

(b) That money in all Funds created by this Resolution, to the extent not invested, shall be secured in the manner prescribed by law for securing funds of the Board, in principal amounts at all times not less than the amounts of money credited to such Funds, respectively.

Section 13. That the Board shall transfer from the Pledged Revenues in the Revenue Fund and deposit to the credit of the Interest and Sinking Fund the amounts, at the times, as follows:

(1) on or before March 25, 1972, and semi-annually on or before each September 25th and March 25th thereafter, an amount which will be sufficient, together with other monies, if any, then on hand therein and available for such purpose, to pay the interest scheduled to accrue and come due on the Bonds on the next succeeding interest payment date; and

(2) on or before March 25, 1972, an amount equal to the principal scheduled to mature and come due on the Bonds on April 1, 1972; and

(3) on or before September 25, 1972, and semi-annually on or before each March 25th and September 25th thereafter, an amount equal to one-half of the principal scheduled to mature and come due on the Bonds on the next succeeding principal maturity date.

Section 14. That on or before March 25, 1972, and semi-annually on or before each September 25th and March 25th thereafter, the Board shall transfer from the Pledged Revenues in the Revenue Fund and deposit to the credit of the Reserve Fund an amount equal to 1/10th of the average annual principal and interest requirements of the Bonds; provided, however, that when the money and investments in the Reserve Fund are at least equal in market value to the amount of the average annual principal and interest requirements of the Bonds, then such deposits may be discontinued, unless and until the Reserve Fund should be depleted to less than said amount in market value, in which case said deposits shall be resumed and continued until the Reserve Fund is restored to said amount; and so long as the Reserve Fund contains said amount, any surplus in the Reserve Fund over said amount may be used to retire any Bonds or Additional Bonds by purchase on the open market, at such price as shall be determined by the Board, or by call for redemption prior to maturity (provided that if any Bond or Additional Bond is subject to call for redemption prior to maturity on the next succeeding interest payment date, its purchase price shall not exceed the redemption price that would be applicable on such date), or such surplus may be used for any other lawful purpose, at the option of the Board.

Section 15. (a) That if on any occasion there shall not be sufficient Pledged Revenues to make the required deposits into the Interest and Sinking Fund and the Reserve Fund, then such deficiency shall be made up as soon as possible from the next available Pledged Revenues, or from any other sources available for such purpose.

(b) That immediately following each required semi-annual deposit from the Revenue Fund to the credit of the Inter-

est and Sinking Fund and the Reserve Fund, as required by this Resolution, or any resolution authorizing the issuance of Additional Bonds, all remaining surplus Pledged Revenues then on deposit to the credit of the Revenue Fund may be used by the Board for any lawful purpose. It is specifically covenanted and agreed, however, that none of the Pledged Revenues in the Revenue Fund (including especially the Pledged General Tuition) will be released from the control of the Board, deposited into the State Treasury of the State of Texas, or otherwise expended or disposed of, until after each such required semi-annual deposit from the Revenue Fund has been made to the credit of the Interest and Sinking Fund and the Reserve Fund.

Section 16. On or before the last day of March, 1972, and semi-annually on or before the last day of each September and of each March thereafter while any of the Bonds or Additional Bonds are outstanding and unpaid, the Board shall make available to the paying agents therefor, out of the Interest and Sinking Fund, and/or the Reserve Fund, if necessary, money sufficient to pay such interest on and such principal of the Bonds and Additional Bonds as will accrue or mature on the April 1st or October 1st immediately following. The paying agents shall totally destroy all paid Bonds and Additional Bonds, and the coupons appertaining thereto, and shall furnish the Board with an appropriate certificate of destruction.

Section 17. That at such times as the aggregate amount of money and investments in the Interest and Sinking Fund and the Reserve Fund are at least equal in market value to (1) the aggregate principal amount of all unpaid (unmatured and matured) outstanding Bonds and Additional Bonds, plus (2) the aggregate amount of all unpaid (unmatured and matured) outstanding interest coupons appertaining to such Bonds and Additional Bonds, no further deposits need be made into the Interest and Sinking Fund or Reserve Fund. In determining the amount of such Bonds and Additional Bonds, and interest coupons appertaining thereto, outstanding at any time, there shall be subtracted and excluded the amount of any such Bonds and Additional Bonds, and interest coupons appertaining thereto, which shall have been duly called for redemption and for which funds shall have been deposited with the paying agents therefor sufficient, including any required redemption premium, for such redemption.

Section 18. That the Bonds and any Additional Bonds, and the interest coupons appertaining thereto, will constitute special obligations of the Board payable solely from the Pledged Revenues, and the holders of the Bonds and Additional Bonds, and the coupons appertaining thereto, shall never have the right to demand payment out of funds raised or to be raised by taxation.

Section 19. That the Board shall have the right and power at any time and from time to time, and in one or more Series or issues, to authorize, issue, and deliver additional parity revenue bonds (herein called "Additional Bonds"), in any amounts, for any lawful purpose, and to refund any Bonds or Additional Bonds. Such Additional Bonds, if and when authorized, issued, and delivered in accordance with this Resolution, shall be secured and payable equally and ratably on a parity with the Bonds, and all other outstanding Additional Bonds, by an irrevocable first lien on and pledge of the Pledged Revenues.

Section 20. (a) The Interest and Sinking Fund and the Reserve Fund established by this Resolution shall secure and be

used to pay all Additional Bonds as well as the Bonds. However, each resolution under which Additional Bonds are issued shall provide and require that, in addition to the amounts required by the provisions of this Resolution and the provisions of any other resolution or resolutions authorizing Additional Bonds to be deposited to the credit of the Interest and Sinking Fund, the Board shall transfer from the Pledged Revenues and deposit to the credit of the Interest and Sinking Fund at least such amounts as are required for the payment of all principal of and interest on said Additional Bonds then being issued, as the same comes due, and that the Board shall transfer from said Pledged Revenues and deposit to the credit of the Reserve Fund at least such amounts, in approximately equal semi-annual installments, as will, together with any other amounts already required to be deposited in the Reserve Fund in connection with the Bonds and any other outstanding Additional Bonds, be sufficient to cause the Reserve Fund to accumulate and contain within a period of not to exceed sixty months after the date of said Additional Bonds then being issued, a total amount of money and investments at least equal in market value to the average annual principal and interest requirements of all Bonds and Additional Bonds to be outstanding after the issuance of the then proposed Additional Bonds.

(b) The principal of all Additional Bonds must be scheduled to be paid or mature on April 1 of the years in which such principal is scheduled to be paid or mature; and all interest thereon must be payable on April 1 and October 1.

Section 21. Additional Bonds shall be issued only in accordance with this Resolution, but notwithstanding any provisions of this Resolution to the contrary, no installment, Series, or issue of Additional Bonds shall be issued or delivered unless:

(a) The senior financial officer of The University of Texas System signs a written certificate to the effect that the Board is not in default as to any covenant, condition, or obligation in connection with all outstanding Bonds and Additional Bonds, and the resolutions authorizing same, and that the Interest and Sinking Fund and the Reserve Fund each contains the amount then required to be therein.

(b) The State Auditor of the State of Texas, or a certified public accountant, signs a written certificate to the effect that, during either the next preceding University of Texas System fiscal year, or any twelve consecutive calendar month period ending not more than ninety days prior to the adoption of the resolution authorizing the issuance of the then proposed Additional Bonds, either the Pledged Revenues were, or the System Tuition was, at least equal to 1.25 times the average annual principal and interest requirements of all Bonds and Additional Bonds to be outstanding after the issuance of the then proposed Additional Bonds.

Section 22. The Board further covenants and agrees that:

(a) It will fix, impose, charge, and collect all Pledged General Tuition; and will faithfully perform at all times any and all covenants, undertakings, stipulations, and provisions contained in this Resolution and each resolution authorizing the issuance of Additional Bonds, and in each and every Bond and Additional Bond; that it will promptly pay or cause to be paid from the Pledged Revenues the principal of and interest on every Bond and Additional Bond, on the dates and in the places and manner



prescribed in such resolutions and Bonds or Additional Bonds; and that it will, at the times and in the manner prescribed, deposit or cause to be deposited from the Pledged Revenues the amounts required to be deposited into the Interest and Sinking Fund and the Reserve Fund; and any holder of the Bonds or Additional Bonds may require the Board, its officials and employees, and any appropriate official of the State of Texas, to carry out, respect, or enforce the covenants and obligations of this Resolution or any resolution authorizing the issuance of Additional Bonds, by all legal and equitable means, including specifically, but without limitation, the use and filing of mandamus proceedings, in any court of competent jurisdiction, against the Board, its officials and employees, or any appropriate official of the State of Texas.

(b) It is duly authorized under the laws of the State of Texas to create and issue the Bonds; that all action on its part for the creation and issuance of the Bonds has been duly and effectively taken, and that the Bonds in the hands of the holders and owners thereof are and will be valid and enforceable special obligations of the Board in accordance with their terms.

(c) It lawfully owns and is lawfully possessed of the lands, buildings, and facilities constituting the Established System Institutions and has a good and indefeasible estate in such lands, buildings, and facilities in fee simple, that it warrants that it has, and will defend, the title to all the aforesaid lands, buildings, and facilities, and every part thereof, for the benefit of the holders and owners of the Bonds and Additional Bonds against the claims and demands of all persons whomsoever, that it is lawfully qualified to pledge the Pledged Revenues to the payment of the Bonds and Additional Bonds in the manner prescribed herein, and has lawfully exercised such rights.

(d) It will from time to time and before the same become delinquent pay and discharge all taxes, assessments, and governmental charges, if any, which shall be lawfully imposed upon it, or the campuses, buildings, and facilities of The University of Texas System, that it will pay all lawful claims for rents, royalties, labor, materials, and supplies which if unpaid might by law become a lien or charge thereon, the lien of which would be prior to or interfere with the liens hereof, so that the priority of the liens granted hereunder shall be fully preserved in the manner provided herein, and that it will not create or suffer to be created any mechanic's, laborer's, material-man's or other lien or charge which might or could be prior to the liens hereof, or do or suffer any matter or thing whereby the liens hereof might or could be impaired; provided, however, that no such tax, assessment, or charge, and that no such claims which might be used as the basis of a mechanic's, laborer's, material-man's or other lien or charge, shall be required to be paid so long as the validity of the same shall be contested in good faith by the Board.

(e) That it will continuously and efficiently operate and maintain in good condition, and at a reasonable cost, The University of Texas System and the facilities and services thereof, so long as any Bonds or Additional Bonds are outstanding.

(f) That while the Bonds or any Additional Bonds are outstanding and unpaid, the Board shall not additionally encumber the Pledged Revenues in any manner, except as permitted in this Resolution in connection with Additional Bonds, unless said encumbrance is made junior and subordinate in all respects to the liens, pledges, covenants, and agreements of this Resolution.

(g) Proper books of record and account will be kept in which full, true, and correct entries will be made of all dealings, activities, and transactions relating to the Pledged Revenues, and all books, documents, and vouchers relating thereto shall at all reasonable times be made available for inspection upon request of any bond holder.

(h) That each year while any of the Bonds or Additional Bonds are outstanding, an audit will be made of its books and accounts relating to the Pledged Revenues by the State Auditor of the State of Texas, or any certified public accountant, such audit to be based on the fiscal year of The University of Texas System. As soon as practicable after the close of each such fiscal year, and when said audit has been completed and made available to the Board, a copy of such audit for the preceding fiscal year shall be mailed to all bondholders who shall so request in writing. Such annual audit reports shall be open to the inspection of the bondholders and their agents and representatives at all reasonable times.

(i) That the Board covenants that it will not permit to be deposited to the credit of any of the Funds created by this Resolution, or applied to the payment of the principal of or interest on the Bonds or any Additional Bonds, any proceeds from any grant, subsidy, donation, or income received from the United States Government, whether pursuant to agreement or otherwise, if such deposit or application would result in interest payable on the Bonds or Additional Bonds being includable in whole or in part in gross income for Federal income tax purposes.

(j) That the Board covenants that it will comply with all of the terms and conditions of any and all grant or subsidy agreements applicable to the Bonds or Additional Bonds entered into between the Board and any governmental agency in connection with any grant or debt service subsidy; and the Board will take all action necessary to enforce said terms and conditions.

(k) That the Board hereby covenants that the proceeds from the sale of said Bonds will be used as soon as practicable for the purpose for which said Bonds are issued; that such proceeds will not be invested in any securities or obligations except for the temporary period pending such use; and that such proceeds will not be used directly or indirectly so as to cause all or any part of the bonds to be or become "arbitrage bonds" within the meaning of Section 103(d) of the Internal Revenue Code of 1954, as amended, or any regulations or rulings prescribed or made pursuant thereto.

Section 23. That the Chairman of the Board is hereby authorized to have control of the Bonds and all necessary records and proceedings pertaining to the Bonds pending their delivery and their investigation, examination, and approval by the Attorney General of the State of Texas, and their registration by the Comptroller of Public Accounts of the State of Texas. Upon registration of the bonds, said Comptroller of Public Accounts (or a deputy designated in writing to act for said Comptroller) shall manually sign the Comptroller's Registration Certificate printed and endorsed on each of the Bonds, and the seal of said Comptroller shall be impressed, or placed in facsimile, on each of the Bonds.

Section 24. That it is hereby officially found and determined: that a case of emergency or urgent public necessity exists which requires the holding of the meeting at which this

Resolution is adopted, such emergency or urgent public necessity being that the proceeds from the sale of said Bonds are required as soon as possible and without delay for necessary and urgently needed public improvements; and that said meeting was open to the public, and public notice of the time, place, and purpose of said meeting was given, all as required by Vernon's Ann. Civ. St. Article 6252-17.

Section 25. That said Bonds are hereby sold and shall be delivered to a Syndicate headed by \_\_\_\_\_, for cash for the par value thereof and accrued interest thereon to date of delivery, plus a premium of \$ \_\_\_\_\_.

-----

C. RECESS

D. RECONVENE, DECEMBER 3, 1971, MAIN BUILDING 212, U. T. AUSTIN. --Following the meetings of the Standing Committees and the Committee of the Whole

E. CONSIDERATION OF MINUTES OF MEETING HELD ON OCTOBER 22, 1971

F. REPORTS OF STANDING COMMITTEES

1. Executive Committee by Committee Chairman Ikard
2. Academic and Developmental Affairs Committee by Committee Chairman Kilgore
3. Buildings and Grounds Committee by Committee Chairman Erwin
4. Land and Investment Committee by Committee Chairman Garrett
5. Medical Affairs Committee by Committee Chairman Williams
6. Board for Lease of University Lands by Regent Garrett or Regent Williams

G. REPORTS OF SPECIAL COMMITTEES, IF ANY

H. REPORT OF COMMITTEE OF THE WHOLE

I. ADJOURNMENT

COMMITTEE OF THE WHOLE  
EXECUTIVE SESSION

December 3, 1971

(Pages 1 - 9, 9a - 91, 10 - 13)

The items listed on the Agenda of the Executive Session of the Committee of the Whole relate either to personnel matters, land acquisition, and security or to items requiring legal consultation.

## BALLOT

Chancellor's Docket No. 52

## Approved except as to the following items:

- Page M16-Item 2: Assuming Dr. John works a 60-hour week and spends  $\frac{1}{4}$  time outside University duties, how does he carry this load?  
Also, what is the Family Medical Center?
- Page M19, Item 24: What does Professor Elmer L. Hixon do with his other two days a week, and which two days are they?
- Page M20, Item 39: Is Allen E. Smith in private practice and, if so, is he able to limit it to eight hours per week while on University salary?
- Item 41: Mark G. Yudof - How much time is required for a University Professor to serve in the actual trial of a lawsuit against the citizens of San Antonio?
- Page M91, Legal Aid Clinic, Item 528: Is this the salary provided that we approved at the last meeting and the amount of money we are going to contribute to the Legal Aid Clinic on behalf of William T. Buckler?
- Page M117, Item 673: This shows the above-mentioned Dr. George L. John to be 100% University time. How do we resolve the conflict?
- Page W3, Item 6: Grant #8669-EO: Just what is the High School Equivalency Program?
- Page W3, Non-Government Contract, Item 1: What is the GED Center?  
Item 2: Is the modern languages Professor the only pre-requisite to do research on Southwest Ethnic Group Relationships?
- Page ST2, Item 1: Is Miss Clapp with or without tenure, and how many such writers are required by this System?
- Page ST4, Item 27: Please explain how you retract tenure.
- Page HO 4 & HO 5: Total travel of \$33,541.32 budgeted and apparently not used and transferred as shown on Page HO5, with no allowance for travel, or is it covered up in some other item?
- Page PH6: Under Population Studies: Just what sort of population studies is the Kaiser Foundation interested in, since they are granting the funds for such a study? And what is the ultimate goal of the researchers?

Also, under the School of Public Health, I would like a breakdown in general terms as to the student body, how many attorneys and other such people constitute this body.

Also, I should like to suggest that all faculty with tenure be listed, along with length of tenure and that the Chancellor's Docket be revised, since all schools do not report their appointments or re-appointments with or without tenure in one general section, so that members of the Board would not have to search out each individual and then wonder whether they have tenure or not.

42. Service Agreement between The University of Texas at Austin and Southern Union Gas Company for gas service to the following University buildings : Lila B. Etter Alumni House, Collections Deposit Library, Balcones Research, Athletic Council in Gregory Gymnasium, The University of Texas Little Campus, Colorado Apartments, Deep Eddy Apartments, Brackenridge Apartments, Art Building Museum and University Printing Division. Period covered is from September 1, 1971 through August 31, 1973.
43. Contract No. F41698-72-0182 between the United States Air Force and The University of Texas at Austin signed by Vice President James H. Colvin, whereby the University will enroll and provide instruction for students who shall be military personnel of the Air Force selected by the Government, in Extension Courses (Evening) and On-Campus Courses (Day). Period covered is from August 24, 1971 until terminated.
44. Grant Agreement for Project OE 124010 between The University of Texas at Austin and the Texas Education Agency, signed by Vice President James H. Colvin, whereby the University agrees to design a research system leading to delineation of adult performance levels in four major sub-areas. Period of the agreement is from June 30, 1971 through June 30, 1972.

OUTSIDE EMPLOYMENT. I recommend that the persons listed below be permitted to undertake the outside duties specified for each, the work to be arranged so as not to interfere with University assignments, and otherwise to conform to Chapter III, Section 13 of Part One of the Rules and Regulations of the Board of Regents for the Government of The University of Texas.

1. Peter T. Flawn, Vice President for Academic Affairs, to act as consultant to the Santa Cruz Mining Company. Approximately 1 day per month.
2. George L. John, M.D., Staff Physician Student Health Center, to perform routine duties of a physician at the Family Medical Center. Approximately 10-15 hours per week.
3. W. Frank Blair, Professor of Zoology, to act as a member of the Environmental Advisory Panel for the Texas Water Development Board. Approximately 6-8 days per year.
4. Anthony Bedford, Assistant Professor of Aerospace Engineering and Engineering Mechanics, to act as consultant on dynamical properties of composite materials for Sandia Laboratories, Albuquerque, New Mexico. Approximately 8 hours per month.
5. Anthony Bedford Assistant Professor of Aerospace Engineering and Engineering Mechanics to act as Technical Editor for Applied Mechanics Review, San Antonio, Texas. Approximately 16 hours per month.
6. W. T. Fowler, Associate Professor of Aerospace Engineering and Engineering Mechanics, to act as consultant with engineers on problems of guidance and control of

power lasers and laser systems for military applications for Tracor, Inc., Military Products Division, Austin, Texas. Approximately 8 hours per month.

24. Elmer L. Hixson, Professor of Electrical Engineering, to act as consultant on instrumentation, measurement and analysis of acoustical and mechanical noise and vibration, for Menasco Manufacturing Company, Fort Worth, Texas; IBM Office Products Division, Austin, Texas, and McCandless Consultants, Inc., Austin, Texas. Approximately 5 days per week.
25. Roy Krezdorn, Associate Professor of Electrical Engineering, to act as consultant to Texas Engineer Associates. Approximately 4 days per month.
26. C. V. Ramamoorthy Professor of Electrical Engineering, to act as consultant in computer design and computer architecture for U. S. Army, Texas Instruments, Inc., Honeywell, Inc., Information Research Associates and Cambridge Memories Inc. Approximately 3 days per month.
27. Philip C. Richardson, Associate Professor of Electrical Engineering, to act as medical consultant on biomedical instrumentation techniques for Medical Monitor Systems, Inc. - approximately 20 hours per month; to act as medical examiner for Metropolitan Life Insurance Company - approximately 1 hour every 3 months.
28. Robert A. Helfinstine, Assistant Professor of Mechanical Engineering, to act as consultant on the design of offshore structures for Esso Production Research Company, Houston, Texas. Approximately 8 hours per month.
29. James R. Holmes, Sr., Associate Professor, Graphics Division of Mechanical Engineering, to advise or sketch how to present engineering data graphically for various individuals in the Department of Mechanical Engineering at The University of Texas at Austin. Approximately 3-4 days per month.
30. Paul A. Jensen, Associate Professor of Mechanical Engineering, to develop techniques to optimally partition electronic systems into replacable modules for UAF System Command, Rome Air Development Center. Approximately 20 hours per month.
31. William L. Oberkampf, Assistant Professor of Mechanical Engineering, to act as consultant in the area of fluid mechanics for Pinson Associates, Austin, Texas. Approximately 15 hours per month.
32. Eldon J. Reynolds, Instructor in Mechanical Engineering, to act as member of Board of Directors, Reynolds Research and Manufacturing Corporation, McAllen, Texas. Approximately 8 hours every two months.
33. H. G. Rylander, Professor of Mechanical Engineering, to act as consultant on design and analysis of mechanical and hydraulic drives for hot-mix asphalt plants for CMI, Inc., of Chatanooga, Tennessee. Approximately 8 hours per month.

34. H. G. Rylander, Professor of Mechanical Engineering, to act as consultant on design and analysis on high speed line sprinters and traction drive transmissions for Tracor, Inc., Austin, Texas. Approximately 4 hours per month.
35. Gary C. Vliet, Associate Professor of Mechanical Engineering, to act as consultant for AFCRL on a contract held by Lockheed Missiles and Space Company to develop and make measurements with an infrared radiometer for Air Force Cambridge Research Laboratory, Cambridge, Mass. Approximately 40 hours to December 31, 1971 and approximately 40 hours from January 1, 1972 through July 1, 1972.
36. G. R. Wagner, Assistant Professor of Mechanical Engineering, to consult on Operations Research project for Honeywell, Inc., Mobil Oil, Texas Instruments, LTV, MRI Systems Corp.; to participate in Management Education in Computer Assisted Decision Making for the University of Wisconsin Extension Division. Approximately 16 hours per month.
37. Hugh A. Walls, Associate Professor of Mechanical Engineering, to act as consultant on heat transfer problems for Northern Natural Gas Company, Omaha, Nebraska. Approximately 3 days per month.
38. F. W. Jessen, Professor of Petroleum Engineering, to act as consultant relating to converting a mined out potash mine bearing oil to additional recovery through solution mining operations for Texas Gulf Sulphur Company, Moab, Utah - approximately 3 days per month; to analyze deep brining operations for Dallow Salt Dome, Geismer, Louisiana; to act as consultant on project to determine maximum size of cavity formation consistent with the stability in prevailing pressure and temperature of the salt mass all for BSAF Wyandotte, Wyandotte, Michigan. Approximately 24 hours per month.
39. Allen E. Smith, Professor of Law, to provide legal representation for various private parties whose interests are not in conflict with those of the University of Texas at Austin or the University of Texas System. Approximately 8 hours per week.
40. John F. Sutton, Jr., William Benjamin Wynne Professor of Law, to act as consultant and prepare legal opinion for University Federal Credit Union. Approximately 5 hours per week for 8 weeks.
41. Mark G. Yudof, Assistant Professor of Law, to act as consultant in Rodrigues v. San Antonio, a suit challenging the Texas plan for financing public education. The complaint alleges that the ability of a school district to support public education is a function of its wealth (assessed value of property) in violation of the equal protection clause for Arthur Gochman, San Antonio, Texas. Approximately 3 hours per week.
42. Louis E. DeMoll, Associate Professor of Social Work, to act as consultant to the Texas Department of Mental Health and Mental Retardation in community mental health and mental retardation services and for inservice training for social work staff. Approximately 1 day per month.



<u>Item, Department, Title, Name</u>	<u>Period of Appointment</u>	<u>% Time</u>	<u>Full-time Salary</u>	
			<u>No. Mos.</u>	<u>Rate</u>
<b>SCHOOL OF LAW</b>				
Transfer of Funds				
527. Amount of Transfer - \$27,000				
To: School of Law - Teaching Assistants (\$15,750)				
From: Unallocated Faculty Salaries (\$11,250)				
School of Law - Reserve for Faculty Salaries (\$4,500)				
To: Unallocated Classified Salaries (\$11,250)				
From: School of Law - Wages (\$11,250)				
The transfer to the Teaching Assistants account is to establish an account within the School of Law from which part-time teaching personnel - formerly "Quizmasters" - may be paid.				
(RBC# 65, 64)				
<u>School of Law - Legal Aid Clinic</u>				
Appointment				
Legal Aid Associate Director				
528. William T. Buckle	9/1 - 8/31	100	12	\$ 11,000
(RBC# 419)				
<u>School of Law and School of Law - Legal Aid Clinic</u>				
Resignation				
529. Barbara Friday				
School of Law				
Lecturer	9/1 - 5/31	50	9	14,000
School of Law - Legal Aid Clinic				
Legal Aid Director	9/1 - 8/31	50	12	15,000
Date of Resignation				
(RBC# 843, 954)				
<u>GRADUATE SCHOOL OF LIBRARY SCIENCE</u>				
Appointment				
Professor				
530. Claud G. Sparks	9/1 - 5/31	100	9	20,000
(RBC# 245)				
Assistant Professor				
531. Donald G. Davis, Jr.	9/1 - 5/31	100	9	12,000
(RBC# 129)				
Lecturer				
532. Julie H. Bichteler	9/1 - 5/31	33	9	10,000
(RBC# 417)				
Transfer of Funds				
533. Amount of Transfer - \$6,000				
To: Graduate School of Library Science - Visiting Lecturers (\$3,000)				
From: Unallocated Visiting Lecturers (\$3,000)				
To: Unallocated Teaching Salaries (\$3,000)				
From: Graduate School of Library Science - Faculty Salaries (\$3,000)				
To transfer to the appropriate account funds to be used for Visiting Lecturers.				
(RBC# 991)				

<u>Item, Department, Title, Name</u>	<u>Period of Appointment</u>	<u>% Time</u>	<u>Full-time Salary</u>	
			<u>No. Mos.</u>	<u>Rate</u>
<u>AUXILIARY ENTERPRISES AND OTHER ACTIVITIES (Continued)</u>				
<u>Division of Housing and Food Service - Jester Center Halls</u>				
<u>Appointment</u>				
Student Development Specialist II				
671. Gretchen A. W. Finn (RBC# 555)	9/1 - 8/31	100	12	\$ 7,800
<u>Student Government</u>				
<u>Resignation</u>				
Financial Director				<u>Stipend</u>
672. Theodore Siff	9/1 - 5/31	P.T.		\$ 675
Date of Resignation (RBC# 997)	8/31/71			
<u>Student Health Center</u>				
<u>Appointment</u>				
Physician, General Medicine				
673. George L. John (RBC# 534)	9/1 - 8/31	100	12	21,000
Physician, Specialist, Psychiatry				
674. John D. Rollyson (RBC# 72)	9/1 - 8/31	10	12	22,000
<u>Appointment and Leave of Absence</u>				
Physician, General Medicine				
675. Travis C. Green	9/1 - 8/31	100	12	18,000
Term of Leave (RBC# 880, 533)	9/16 - 10/10			
<u>Change of Status</u>				
Physician, Specialist, Gynecology				
676. Fred G. DuPuy				
To:	9/1 - 8/31	55	12	24,000
From:	9/1 - 8/31	33	12	24,000
(RBC# 882)				
<u>Resignation</u>				
Physician, General Medicine				
677. Thomas P. Leonard	9/1 - 8/31	50	12	20,000
Date of Resignation (RBC# 70)	8/31/71			

Sincerely yours,

*Stephen H. Spurr*

Stephen H. Spurr  
President

GOVERNMENT CONTRACTS AND GRANTS (CONTINUED)

6. Grant No. 8669-E/O, dated September 28, 1971, whereby the Assistant Director for Operations, Office of Economic Opportunity, Washington, D. C. 20506, awards \$239,016 in additional funding for the continuation of the High School Equivalency Program during the period September 1, 1971 through August 31, 1972. \$3,000 in carry-over funds must be assigned to this program year for a total federal share of \$242,016.

7. Project No. 14905072, dated August 20, 1971, whereby the Texas Education Agency, Division of Teacher Education and Certification, 201 East 11th Street, Austin, Texas 78701, Our Lady of the Lake College and The University of Texas at El Paso agrees to provide the personal services of Sister Virginia Clare as a Change Agent trainee on the Texas Performance-Based Trainers of Teacher Trainers Project, during the period beginning September 30, 1971 and ending May 31, 1972. For these services the Texas Education Agency shall provide financial support for travel expenses not to exceed \$1,000 and salaries and wages not to exceed \$8,000.

NON-GOVERNMENT CONTRACTS AND GRANTS

I recommend acceptance of the following grants and contracts which have been received:

1. Annual Contract, dated September 20, 1971, whereby the Administrator, GED Testing Service, One Dupont Circle, Washington, D. C. 20036, enters into an agreement with The University of Texas at El Paso for the operation of an Official GED Center for a period of one year beginning on the first day of the month after shipment of test materials.

2. Grant from The Spencer Foundation, John Hancock Center, 875 North Michigan Avenue, Chicago, Illinois 60611, which provides the sum of \$63,701 for the support of research on Southwest Ethnic Group Relationships. The grant is effective for the period September 1, 1971 through August 31, 1973, and the research will be under the direction of Dr. Jacob Ornstein, Professor of Modern Languages, and Dr. Z. A. Kruszewski, Associate Professor of Political Science.

RECOMMENDED AMENDMENTS TO 1970-71 BUDGET

EDUCATIONAL AND GENERAL

RESIDENT INSTRUCTION

SCHOOL OF SCIENCE

Physics

1. Transfer of Funds:

From: Travel	\$277.15
To: Maintenance and Operation	277.15
For: Transfer between dissimilar appropriations to allow the department to service its needs more effectively. (RBC 453)	

REAPPROPRIATION OF FUNDS

2. Approve the reappropriation of the following balance from the 1970-71 Budget. (RBC 455)

Office of Institutional Studies - Maintenance and Operation	\$ 458.73
Operation and Maintenance of Physical Plant:	
General Services - Maintenance and Operation	1,407.43
	<u>\$1,866.16</u>

RECOMMENDED AMENDMENTS TO 1971-72 BUDGET

The following amendments to the 1971-72 budget are written on the basis of "budget rates" rather than the "freeze rates" resulting from the President's Executive Order. For the duration of the wage-price freeze, while reported amendments to the budget are based on budget rates, all payrolls are processed in compliance with the rules, regulations, and guidelines issued under authority of the Executive Order.

EDUCATIONAL AND GENERAL

GENERAL ADMINISTRATION AND STUDENT SERVICES

Office of the Registrar

1. Appoint Robert L. Schumaker as Director of Admissions and Operations (2/3 Time) effective September 1, 1971 through January 15, 1972 and Director of Admissions and Operations (Full-time) effective January 16 through August 31, 1972, at his annual rate of \$17,333.00 with the necessary funds in the amount of \$15,167.00 to come from unallocated salaries. He will also serve as Associate Professor (1/3 Time) in the Department of Physics for the 1971 Fall Semester. (RBC 112)

National Heart and Lung Institute

Change in Grant Previously Approved:

4. Research Grant Supplement 3 RO1 HE13347-01S1  
Formation of Cellular Pseudointimas  
Dr. John J. Ghidoni  
September 1, 1971 - June 30, 1972  
\$1,323

National Institute of Mental Health

5. Research Grant 1 RO1 MH20028-01  
Epidemiology of Acceptance of Mental Health Services  
Dr. Gustavo M. Quesada  
September 1, 1971 - August 31, 1972  
\$33,938

Change in Grant Previously Approved:

6. Research Grant 1 RO1 MH18174-01  
Study of Risk Taking Among Suicide Attempters  
Dr. Martin B. Giffen  
Extension of time until December 31, 1971  
No additional funds

CONTRACTS AND AGREEMENTS (OTHER): Approval is requested for the following:

Bexar County Hospital District

Change in Contract Previously Approved:

1. Change the amount of BCHD Contract #5 ending December 31, 1971 from \$722,885.00 to \$693,209.72

RECOMMENDED AMENDMENTS TO THE 1971-72 BUDGET:

The following amendments to the 1971-72 budget are written on the basis of "budget rates" rather than the "freeze rates" resulting from the President's Executive Order. For the duration of the wage-price freeze, while reported amendments to the budget are based on budget rates, all payrolls are processed in compliance with the rules, regulations, and guidelines issued under authority of the Executive Order.

Office of Media & Community Information

1. Appoint Miss Marjorie A. Clapp as Assistant to the Director of Media & Community Information at an annual salary rate of \$12,500 effective September 1, 1971. (RBC 33)

Office of Academic Development

2. Reappoint Dr. Carlos Pestana as Associate Dean for Academic Development (50% time) at an annual salary rate of \$19,500. Dr. Pestana is also Associate Professor (T) (50% time) in the Department of Surgery. Transfer unused salaries in the amount of \$16,750 to Unallocated Administrative and Professional Salaries. (RBC 17)

Office of Graduate and Sponsored Programs

3. Change the status of Dr. Adah E. Verder from Assistant to the Graduate Program Administrator (75% time) to Assistant to the Graduate Program Administrator (100% time) at an annual salary rate of \$25,000 effective September 1, 1971. Dr. Verder also serves as Visiting Professor in the Department of Microbiology (without salary). (RBC 41)

16. Reappoint Dr. Stephan N. Schanzer as Associate Professor (20% time) at an annual salary rate of \$24,000 effective September 1, 1971. Transfer unused Teaching Salaries in the amount of \$19,200 to Unallocated Faculty Salaries. (RBC 16)

Pathology

17. Correct the budgeted salary rate of Mr. Gary R. Doyle from \$12,000 to \$11,500 effective September 1, 1971. Mr. Doyle will receive \$10,200 from Pathology, Teaching Salaries and \$1,300 from Gifts from MSRDP-Pathology. (RBC 14)

Pediatrics

18. Reappoint Dr. Fernando A. Guerra as Instructor (25% time) at an annual salary rate of \$18,000 effective September 1, 1971. Funds needed for this reappointment to come from Pediatrics, Teaching Salaries. (RBC 2)

19. Change Dr. Eleanor A. Eller from Assistant Professor (16.6% time) to Assistant Professor (25% time) at an annual salary rate of \$20,000 effective September 1, 1971. Additional funds needed for this change to come from Pediatrics, Teaching Salaries. (RBC 3)

20. Change the source of funds and title of Dr. Robert A. DeLemos from Assistant Professor (33% time) at an annual salary rate of \$18,000 from Gifts from MSRDP - Pediatrics to Clinical Associate Professor (33% time), Pediatrics Teaching Salaries, effective September 1, 1971. Transfer unused Teaching Salaries in the amount of \$5,833 to Unallocated Faculty Salaries. (RBC 4)

21. Change the source of funds of Dr. Edgar O. Ledbetter, Associate Professor (33% time) at an annual salary rate of \$19,000 from DHEW Grant 5 EO3 ME00172-05 to BCHD Contract #5 effective September 1, 1971 through December 31, 1971. (RBC 5)

22. Appoint Dr. Robert A. Kimbrell as Instructor at an annual salary rate of \$18,000 effective September 13, 1971 through June 30, 1972. (RBC 39)

23. Appoint Dr. Max I. Michels as Clinical Associate Professor (18.75% time) at an annual salary rate of \$24,000 effective October 1, 1971 through August 31, 1972. Transfer unused teaching salaries in the amount of \$3,475 to Unallocated Faculty Salaries. (RBC 40)

24. Change the status of Dr. Eleanor A. Eller from Assistant Professor (25% time) to Assistant Professor (33.33% time) at an annual salary rate of \$20,000 effective October 1, 1971 through October 31, 1971. (RBC 44)

25. Reappoint Dr. Eleanor A. Eller as Assistant Professor (25% time) at an annual salary rate of \$20,000 effective November 1, 1971. (RBC 49)

Pharmacology

26. Appoint Dr. Kenneth Blum as Assistant Professor at an annual salary rate of \$18,500 effective November 1, 1971. Transfer unused Teaching Salaries in the amount of \$3,583.30 to Unallocated Faculty Salaries. (RBC 53)

Psychiatry

27. Correct the status of Dr. Orie L. Forbis, Jr. from Associate Professor (T) to Associate Professor (without tenure) at an annual salary rate of \$26,500 effective September 1, 1971. (RBC 6)

28. Change the budgeted status of Miss Margaret S. Keir, Instructor (Psychology) at an annual salary rate of \$10,500 (100% time) to Instructor (57.14% time) effective September 1, 1971 through December 31, 1971. Funds needed for this change to come from BCHD Contract #5. (RBC 15)

RECOMMENDED AMENDMENTS TO THE 1970-71 BUDGET - continued

\* Transfer of Funds - continued

From: Unallocated Appropriations	
Maintenance and Operation	\$ 5,000.00
	TOTAL SOURCE
	<u>\$387,472.00</u>
To: Neurobiology Section	
Maintenance and Operation	\$ 723.01
Pharmacology	
Classified Salaries	1,540.00
Travel	38.41
Physiology	
Faculty Salaries	.01
Administrative & Professional Salaries	2,135.81
Classified Salaries	1,732.65
Ophthalmology	
Classified Salaries	560.50
Maintenance and Operation	226.66
Travel	212.44
Reproductive Biology	
Classified Salaries	620.00
Biomedical Communications	
Classified Salaries	737.82
Office of the Dean	
Maintenance and Operation	468.48
Travel	151.94
Office of the Associate Dean	
for Business Affairs	
Classified Salaries	300.00
Office of the Associate Dean	
for Academic Affairs	
Classified Salaries	3,055.73
Office of the Associate Dean	
for Health Affairs and Planning	
Classified Salaries	350.94
Office of the Director of Accounting	
Maintenance and Operation	1,095.21
Office of the Director of General Stores	
Classified Salaries	571.59
Maintenance and Operation	196.05
Personnel Director	
Maintenance and Operation	6,571.90
Telephone and Telegraph Service	
Maintenance and Operation	6,871.19
Planning Consultants	
Maintenance and Operation	5,380.98

RECOMMENDED AMENDMENTS TO THE 1970-71 BUDGET - continued



Transfer of Funds - continued

To: Internal Medicine Equipment	\$ 80,000.00
Pathology Equipment	80,000.00
Pediatrics Equipment	80,000.00
Psychiatry Equipment	80,000.00
General Institutional Equipment Equipment	<u>33,930.68</u>
TOTAL APPLICATION	<u>\$387,472.00</u>

For: These funds are being transferred to close 1970-71 General Operating Budget accounts and reallocate balances to provide funds for instructional equipment.

RECOMMENDED AMENDMENTS TO THE 1971-72 BUDGET: The following amendments to the 1971-72 budget are written on the basis of "budget rates" rather than the "freeze rates" resulting from the President's Executive Order. For the duration of the wage-price freeze, while reported amendments to the budget are based on budget rates, all payrolls are processed in compliance with the rules, regulations, and guidelines issued under authority of the Executive Order.

GENERAL ADMINISTRATION

Office of the Dean

1. Reappoint Jon H. Fleming, Ph.D. as Assistant to the Dean at a salary rate of \$15,000 for 12 months, effective September 1, 1971. Funds needed are to come from departmental Administrative and Professional Salaries. (RBC No. 15)

Office of the Personnel Director

2. Transfer of Funds: (RBC No. 16)

From: Office of the Director of General Services Classified Salaries	<u>\$5,268.00</u>
To: Office of the Personnel Director Classified Salaries	<u>\$5,268.00</u>

For: This transfer is requested to provide funds for the creation of a position of Clerk-Typist II at an annual rate of \$5,268.

INSTRUCTION AND DEPARTMENTAL RESEARCH

Pharmacology

3. Appoint Dr. G. Alan Robison as Professor of Pharmacology at a salary rate of \$33,500 for 12 months, effective April 1, 1972. Funds needed are to come from departmental Faculty Salaries. Dr. Robison is also to serve as Director of the Program in Pharmacology. (RBC No. 4)

00016-02 to Professor of International Health, payable at the rate of \$25,000.00 per annum from International Health (General Funds), effective September 1, 1971. This perpetuates action taken on Regents Budget Change No. 79 (70-71). (RBC 32)

Institute of Environmental Health

42. Reappointment: Reappoint Jane L. Valentine, Research Associate, payable at the rate of \$4,500.00 per annum from NASA Contract #NAS 9-11701, effective September 1, 1971. This perpetuates action taken on Regents Budget Change No. 101 (70-71). (RBC 33)

43. Change in Time Assignment: Change the time assignment for Dr. Stanley M. Pier, Adjunct Associate Professor of Environmental Health, from the fifty percent time rate of \$12,500.00 per annum from General Funds to full time, payable at the rate of \$12,500.00 per annum from Institute of Environmental Health (General Funds) and \$12,500.00 per annum from NASA Contract NAS 9-11701, effective September 1, 1971. This perpetuates action taken on Regents Budget Change No. 104 (70-71). (RBC 34)

44. Reappointment: Reappoint Dr. Richard K. Severs, Assistant Professor of Environmental Health, payable at the rate of \$7,000.00 per annum from General Funds and the rate of \$8,000.00 per annum from NASA Contract NAS 9-12041, effective September 1, 1971. This perpetuates action taken on Regents Budget Change No. 113 (70-71). (RBC 35)

45. Reappointment: Reappoint William F. Dunn, Research Associate, payable at the rate of \$3,233.33 per annum from NASA Contract NAS 9-12040, effective for the period September 1, 1971, through September 30, 1971. (RBC 41)

46. Change in Salary Support: Change the source of salary support for Dr. Harold E. Eitzen, Assistant Research Environmental Scientist, from the rate of \$17,000.00 per annum from NASA Contract 9-11384 to the rate of \$17,000.00 per annum from General Funds, effective September 16, 1971. (RBC 42)

\* Population Studies

47. Reappointment: Reappoint Dr. Robert E. Roberts, Associate Research Demographer, payable at the rate of \$5,500.00 per annum from Population Studies (General Funds), the rate of \$5,500.00 per annum from Kaiser Foundation Hospital Grant and the rate of \$11,000.00 per annum from Regional Medical Program Grant 2-G03-RM-00007-03, Project 1016, effective September 1, 1971. This perpetuates action taken on Regents Budget Change No. 43 (70-71). (RBC 36)

48. Reappointment: Reappoint Paul W. Callen, Research Associate, payable at the fifty percent time rate of \$7,250.00 per annum from General Funds, effective September 1, 1971. (RBC 37)

49. Change in Salary Support: Change the source of salary support for Dr. Eun Sul Lee, Assistant Research Biometrician, from the full time rate of \$16,000.00 per annum from the Population Studies (General Funds) to the twenty-five percent time rate of \$4,000.00 from Regional Medical Program Grant 5-G03-RM00007-04, Project No. 1016 and the seventy five percent time rate of \$12,000.00 per annum from Population Studies (General Funds), effective September 1, 1971. (RBC 47)

50. Change in Salary Support: Change the source of salary support for Dr. Robert E. Roberts, Associate Research Demographer, from the rate of \$5,500.00 per annum from Population Studies (General Funds), the rate of \$5,500.00 per annum from Kaiser Foundation Hospital Grant and the rate of



COMMITTEE OF THE WHOLE  
EXECUTIVE SESSION

December 3, 1971

(Pages 1 - 9, 9a - 9l, 10 - 13)

The items listed on the Agenda of the Executive Session of the Committee of the Whole relate either to personnel matters, land acquisition, and security or to items requiring legal consultation.

BOARD OF REGENTS OF THE UNIVERSITY OF TEXAS SYSTEM  
December 3, 1971

STRICTLY  
EXECUTIVE SESSION

	<u>Page No.</u>
1. U. T. Austin: Proposed Professorship	2
2. U. T. Austin: Nominations to the Advisory Council of the Engineering Foundation	6
3. U. T. Austin: Legal Matters Concerning Student Publications	9
4. U. T. Austin: Budgetary and Personnel Matters Relating to Post-Season Game	10
5. U. T. El Paso: Nominations to The University of Texas at El Paso Development Board	10
6. U. T. Permian Basin: Legal Matters Relating Thereto	12
7. Galveston Medical Branch: Nomination to National Scientific Advisory Board of the Marine Biomedical Institute	13
8. Galveston Medical Branch: Legal Matters Regard- ing Possible Sale of Bonds for Expansion of John Sealy Hospital and Other Facilities	13
9. Legal Aspects re Gifts (Dr. Ransom)	13

1. U. T. Austin: Establishment of a Distinguished Visiting Professorship in the Lyndon B. Johnson School of Public Affairs. --

Chancellor LeMaistre concurs in President Spurr's recommendation that authorization be given to proceed with arrangements to accept a gift from the Tom Slick Estate, the income from which will be used to establish a Distinguished Visiting Tom Slick Professorship of World Peace in the Lyndon B. Johnson School of Public Affairs at The University of Texas at Austin.

The amount of the gift is dependent upon resolution of some contingencies in the Estate but will be in excess of \$750,000 and possibly as high as \$900,000.

The purpose of this Professorship is to provide a yearly focus for a continuing program of research, graduate education, public enlightenment, and an international forum for the examination of the knowledge and institutional requirements for lasting world peace.

To this end a distinguished visitor would be invited to spend a year at the School to conduct ten seminar sessions, deliver two public lectures to be published in the School's occasional paper series, and plan and conduct a major conference to draw on participants from throughout the United States and other countries.

Charles A. LeMaistre, M.D.  
Chancellor  
The University of Texas System

November 1, 1971

REC'D NOV 3 1971  
To: ..... For info and  
To: ..... Please Adv  
To: ..... Please Adv

Dear Dr. LeMaistre:

May I transmit with my approval the request outlined in the attached documents to establish a Distinguished Visiting Tom Slick Professorship of World Peace in the Lyndon B. Johnson School of Public Affairs. I hope that this proposal will receive your approval and that of the Board of Regents at its meeting scheduled for December 3, 1971.

In view of the nature of the relationship between The University of Texas at Austin and the executors and trustees of the Tom Slick Estate, I share Mr. Blunk's opinions that this item would be most appropriately discussed by the Regents in Executive Session. Please note in this regard Mr. Blunk's comment in the attached memorandum to me concerning the need for maintaining confidentiality in this matter.

Sincerely yours,

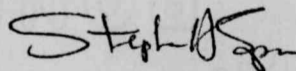

Stephen H. Spurr  
President

SHS:ph

Attachments

cc: Mr. Blunk  
Dean Gronouski



THE UNIVERSITY OF TEXAS AT AUSTIN  
 DEVELOPMENT BOARD  
 AUSTIN, TEXAS 78712

PRESIDENT'S OFFICE U. T. AUSTIN	
REC'D	OCT 12 1971
REFER TO _____	
HANDLE _____	
COMMENT & RETURN _____	
FILE OR DISCARD _____	

October 11, 1971

*RM*

MEMORANDUM

TO: President Stephen H. Spurg  
 FROM: W. D. Blunk *W.D. Blunk*  
 SUBJECT: The proposed Distinguished Visiting Tom Slick Professorship of World Peace.

Dean John A. Gronouski has given me the attached file on a proposal from the Executors and Trustees of the Tom Slick Estate to fund the Distinguished Visiting Tom Slick Professorship of World Peace at the LBJ School of Public Affairs.

The proposal outlined meets all current standards and requirements for the establishment of a chair, and I recommend that you seek the approval of the Board of Regents to proceed.

No publicity should be given this matter without the approval of Dean Gronouski and the Executors and Trustees of the Tom Slick Estate.

WDB:ld  
 Attachments

cc: Chancellor Charles A. LeMaistre  
 Dean John A. Gronouski

*Approved*  
*Stephen H. Spurg*  
 11/1/71



THE UNIVERSITY OF TEXAS AT AUSTIN  
LYNDON B. JOHNSON SCHOOL OF PUBLIC AFFAIRS  
AUSTIN, TEXAS 78712

Office of the Dean

October 6, 1971

Mr. William D. Blunk  
Executive Director  
University Development Board  
Littlefield Home

Dear Mr. Blunk:

The Lyndon B. Johnson School of Public Affairs has been designated to receive a substantial endowment gift from the Tom Slick Estate. The income for this endowment will be used to support activities related to world peace.

While the exact size of the gift is dependent on some still unresolved contingencies in the Estate, it will be in excess of \$750,000 and probably not more than \$900,000.

I trust it is possible on the basis of this letter and the attachments for you to request on behalf of the LBJ School of Public Affairs approval by the Board of Regents for acceptance of this gift by the University.

With my best wishes.

Sincerely yours

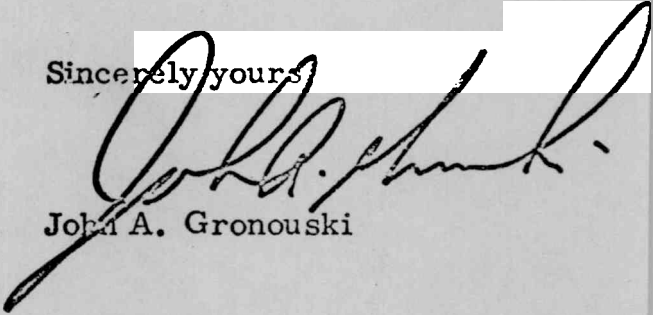
  
John A. Gronouski

JAG:as  
Attachments

LAW OFFICES OF  
COX, SMITH, SMITH, HALE & GUENTHER  
INCORPORATED

800 NATIONAL BANK OF COMMERCE BUILDING  
SAN ANTONIO, TEXAS 78205

AREA CODE 512  
224-4281

JOHN J. COX (1003-1971)  
J. BURLESON SMITH  
PAUL H. SMITH  
JAMES R. HALE  
JACK GUENTHER  
DAVID C. SPOOR  
DAN G. WEBSTER III  
RICHARD T. BRADY  
JOE P. SNYER  
EUGENE B. LABAY  
WAYNE T. WEBER  
T. DREW CAUTHORN  
TERRY S. BICKERTON  
LEONARD BLAYLOCK  
DONALD R. COMUZZI  
BRICE A. TONDRE

September 21, 1971

SEP 22 1971

Dean John A. Gronouski  
Lyndon B. Johnson School of Public Affairs  
University of Texas  
Austin, Texas

Dear Dean Gronouski:

The Executors and Trustees of the Tom Slick Estate have determined to fund the proposed "Distinguished Visiting Tom Slick Professorship of World Peace" with that portion of Mr. Slick's residual estate designated for furthering long-range peace efforts. I have been requested by the Executors and Trustees to go forward with implementing their decision.

I recall that in our last meeting on August 24 you and Dean Clark suggested that you would want to amplify the proposal that you made then, and I will need to do some additional thinking about the "paperwork". It seems to me, however, that since this overall matter must be approved by the Board of Regents, a good starting place would be in prior arrangements approved by the Board, perhaps emanating from the Board of Development. I would appreciate your considering this overall matter and calling me at your convenience so that we might go forward.

Best personal regards to you and to Dean Clark.

Sincerely,

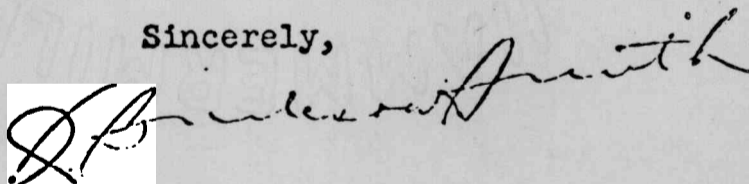

JBS:sv

2. U. T. Austin: Nominations to the Advisory Council of the Engineering Foundation. --

Chancellor LeMaistre concurs in the recommendation of President Spurr and Dean Gloyna that Mr. Gordon Hurlbert, Executive Vice President, Power Generation, Westinghouse Electric Corporation, Westinghouse Building, Gateway Center, Pittsburgh, Pennsylvania, be appointed to the Advisory Council of the Engineering Foundation for an initial term effective September 1, 1971 and ending August 31, 1974; and requests the Board's approval of this nomination.

Since the by-laws of the College of Engineering Foundation permit the appointment of faculty members from the College of Engineering to the Advisory Council of this Foundation, Chancellor LeMaistre also concurs in the recommendation of President Spurr and Dean Gloyna that the Board approve the nomination of the two individuals listed below for the terms indicated.

Dr. Robert S. Schechter, Professor of Chemical Engineering  
(Term expires August 31, 1974.)

Dr. Herbert H. Woodson, Professor of Electrical Engineering  
(Term expires August 31, 1973.)

Following this approval, and acceptance by these nominees, this matter will be reported for the record at a later meeting.

October 20, 1971

REC'D	OCT 21 1971
REFER TO	RM
HANDLE	_____
COMMENT & RETURN	_____
FILE OR DISCARD	_____

MEMORANDUM

TO: Dr. Stephen H. Spurr

FROM: W. Graves Blanton *WGB*

SUBJECT: Nomination to the Advisory Council of the Engineering Foundation

The following person has been nominated by Dean Earnest F. Gloyna for an initial appointment to a three-year term ending August 31, 1974:

Mr. Gordon Hurlbert, Executive Vice President, Power Generation, Westinghouse Electric Corporation, Westinghouse Building, Gateway Center, Pittsburgh, Pennsylvania 15222.

Will you please secure the necessary approval from the Board of Regents.

WGB:ls

cc: Dr. Earnest F. Gloyna

*Approved*  
SHS  
10/21/71



PRESIDENT'S OFFICE U. T. AUSTIN	
REC'D	NOV 4 1971
REFER TO	RM
HANDLE	<input checked="" type="checkbox"/>
COMMENT & RETURN	<input type="checkbox"/>
FILE OR DISCARD	<input type="checkbox"/>

THE UNIVERSITY OF TEXAS AT AUSTIN  
DEVELOPMENT BOARD  
AUSTIN, TEXAS 78712

November 3, 1971

MEMORANEUM

TO: Dr. Stephen H. Spurr, President

FROM: W. Graves Blanton, Associate Director *GFB*

SUBJECT: Nominations to the Advisory Council of the College of Engineering Foundation

The following persons have been nominated by Dean Earnest F. Gloyna for an initial appointment as faculty members of the College of Engineering Foundation Advisory Council:

Dr. Robert S. Schechter, Professor of Chemical Engineering  
(Term expires August 31, 1974.)

Dr. Herbert H. Woodson, Professor of Electrical Engineering  
(Term expires August 31, 1973.)

Will you please secure the necessary approval from the Board of Regents.

WGB:ls

cc: Dr. Earnest F. Gloyna





THE UNIVERSITY OF TEXAS AT AUSTIN  
OFFICE OF THE PRESIDENT  
AUSTIN, TEXAS 78712

November 5, 1971

Charles A. LeMaistre, M.D.  
Chancellor  
The University of Texas System

Dear Dr. LeMaistre:

May I transmit with my approval the nominations to the Advisory Council of the College of Engineering Foundation as indicated on the attached memorandum to me from Mr. Graves Blanton.

Sincerely yours,

A handwritten signature in cursive script that reads "Stephen H. Spurr".

Stephen H. Spurr  
President

SHS:ph

cc: Graves Blanton

3. U. T. Austin: Legal Matters Concerning Student Publications. -- Chairman Peace reports that the appropriate officials have taken the following steps with regard to student publications at The University of Texas at Austin. It is recommended that the Official Minutes include the documents set out herein:
- a. The executed Declaration of Trust (Pages 9a - 9g ) was delivered to Mr. Joe Latting, attorney for Texas Student Publications, Inc., on October 1, 1971.
  - b. A Certificate of Dissolution (Pages 9h - 9i ) dissolving the nonprofit corporation formerly known as Texas Student Publications, Inc., was issued by the Secretary of State on October 1, 1971.
  - c. The lawsuit styled Board of Regents, et al., v. Texas Student Publications, et al. (Pages 9j - 9k ) was dismissed on October 1, 1971.
  - d. Mr. James Colvin and Mr. L. L. Edmonds were directed to carry out the orderly conveyance, assignment, and transfer of all of the assets of the corporation formerly known as Texas Student Publications, Inc., to the Board of Regents of The University of Texas System, in trust, subject to the terms of the Declaration of Trust.
  - e. In accordance with Section 16 of the Declaration of Trust Agreement, President Spurr has promulgated the Operating Procedures (Page 9l ) for the Board of Trustees of student publications at The University of Texas at Austin.

Minutes  
Meeting of the Board of Directors  
Texas Student Publications, Inc.  
Friday, August 27, 1971

VOTING MEMBERS PRESENT: Bob Binder, Eugene Sauls, David Mincberg, Tim Donahue, John Fox, David Stok, Norris Davis.

VOTING MEMBERS ABSENT: Frank Pierce, Charles Bonjean.

NON-VOTING MEMBERS PRESENT: Margaret Berry, Loyd Edmonds, Bob Hilburn, Lori Rodriguez, Jack Stockton, Jan Andrews, Larry Honig, Mack Murrah.

NON-VOTING MEMBERS ABSENT: Stephen Whittaker, John Reetz.

VISITORS PRESENT: Dolores Moore, secretary; Joe Latting and Tom Gee, attorneys.

The meeting was called to order by chairman Binder at 5:50 p.m. in Journalism Building 305.

I. CONSIDERATION OF MOVING INTO EXECUTIVE SESSION: Binder said that because matters of litigation would be discussed, the board should go into executive session.

MOTION NO. 1: Binder moved and it was seconded that the board go into executive session. This motion passed with five voting for and none against.

II. CONSIDERATION OF PROPOSED DECLARATION OF TRUST: Binder requested that all matters discussed in executive session be kept completely confidential. Latting and Gee reviewed what had transpired since the last TSP board meeting concerning the litigation and discussions between the parties. Provisions of the proposed Declaration of Trust were discussed at length. (The complete proposed Declaration of Trust appears as Appendix A in the minutes.)

MOTION NO. 2: Donahue moved, seconded by Mincberg that:

1. The 1970-71 TSP Budgets be amended by increasing the allowance for legal expenses from \$4,000 to a total of \$16,000.
2. The proposed Declaration of Trust that appears as Appendix A in these minutes be accepted and offered for execution to the Board of Regents of The University of Texas.
3. The legal action taken by TSP against the Regents be dismissed with prejudice.
4. The corporation known as Texas Student Publications, Inc. be dissolved.

All four provisions are contingent on the Regents approval of the following:

1. The revised budgets providing a total of \$16,000 for legal expenses.
2. Execution of the Declaration of Trust.
3. The TSP Board's proposal to convey its assets to the Regents pursuant to the provisions of the Declaration of Trust.
4. Dismissing the law suit against all defendants with prejudice.

This motion passed with Davis, Binder, Donahue, Sauls, Stok and Mincberg voting for; Fox voting against.

Once again the board was reminded by both Latting and Gee that the matter was not settled and there should be no discussion of the matters discussed in executive session.

III. DISCUSSION ON ACTION OF TSP MANAGING EDITOR CONCERNING APPOINTMENTS: The board was told that Reetz, the newly appointed Managing Editor of the Texan, had not followed the board's suggestion in giving Steve Wisch a position on the permanent staff. Members of the board expressed concern that Reetz had not followed the board's suggestion.

The meeting adjourned at 7:50 p.m.

DECLARATION OF TRUST

Texas Student Publications, Inc., acting by and through the undersigned as officers and directors, and the undersigned as officers and directors hereby convey, assign and transfer all assets of Texas Student Publications, Inc., of every kind and character, including, but not limited to, cash, bank accounts, personal property and real property, to the Board of Regents of The University of Texas System (hereinafter referred to as "Trustees") in trust, subject to the terms and conditions of this instrument.

1.

There is hereby created an Operating Board of Trustees, hereinafter called "Operating Trustees", who shall operate as hereinafter provided.

2.

All assets of Texas Student Publications, Inc., are hereby delivered to the Trustees and recorded in the accounting records of The University of Texas at Austin, to be used solely for the maintenance and support of the Texas student publications described in Paragraph 4 below. The recording, budgeting and expenditure of these assets will be in accordance with the Trustees' Rules and Regulations for the management of this type of funds and account.

3.

The operations of student publications on the campus of The University of Texas at Austin are under the control and jurisdiction of the Operating Trustees, constituted as hereinafter set out. All actions of the Operating Trustees and all business connected with student publications on the campus of The University of Texas at Austin conducted by them shall be pursuant to, subject to and in accord with Trustees' Rules and Regulations.

4.

The Operating Trustees are responsible for the issuance, publication and distribution of the student publications on the campus of The University of Texas at Austin. Such publications presently consist of The Daily Texan, The Summer Texan, The Texas Ranger Magazine, Cactus, Peregrinus, Texas Engineering and Science Magazine, and Riata. The Operating Trustees may authorize other publications.

5.

The Board of Operating Trustees is composed of eleven voting members, composed as follows:

- A. Four undergraduate students out of the Journalism Department of The University of Texas at Austin, elected (two to be elected in even-numbered years and two to be elected in odd-numbered years after the initial election; at the initial election under these rules all four shall be elected with provision for staggered terms as hereinafter set out) by those students certified by the chairman of such department as being journalism majors. Said election is to be held at least three weeks before the spring government election each year pursuant to the rules established by the Operating Trustees. No student shall be eligible to be a candidate for a position on the Board of Operating Trustees unless he has completed or will have completed by the end of the spring semester in which the election is held twelve hours of journalism courses, is in good standing (not on scholastic probation), and has completed at least one semester in residence in the long term at The University of Texas at Austin. The eligibility of a candidate must be certified to by the chairman of the Department of Journalism prior to the time of said election.
- B. Two undergraduate students elected at large from the student body of The University of Texas at Austin (one to be elected in even-numbered years and one to be elected in odd-numbered years after the initial election, at the first election under these rules both shall be elected with provision for staggered terms as hereinafter set out) at the same time as

the editor of The Daily Texan, pursuant to Section 11 hereof. If the President of the Students' Association is not one of the students elected at the election, then the President of the Students' Association shall serve as an ex officio member of the Board of Operating Trustees without vote.

- C. Two members of the faculty out of the voting faculty of the Department of Journalism and one member of the faculty out of the voting faculty of the College of Business Administration, all three to be appointed directly by the President of The University of Texas at Austin.
- D. Two professional newspapermen appointed by the President of The University of Texas at Austin.

6.

Voting members of the Board of Operating Trustees shall serve a term of two years beginning June 1 of each calendar year. However, in order to provide staggered terms the following procedure shall be used concerning the first Board of Operating Trustees under this section, to take office on June 1, 1972.

- A. The four journalism students elected from the Department of Journalism shall draw lots in the presence of a quorum of the Board of Operating Trustees to determine which two shall serve initial terms of one year and which two shall serve initial terms of two years.
- B. The two undergraduate students elected at large from the student body of The University of Texas at Austin shall draw lots in the presence of a quorum of the Board of Operating Trustees to determine which one shall serve an initial term of one year and which one shall serve an initial term of two years.
- C. The President of The University of Texas at Austin shall appoint one of the faculty out of the Department of Journalism for an initial term of one year, and he shall appoint the other journalism faculty member for an initial term of two years. The President of The University of Texas at Austin shall appoint the remaining faculty member for an initial term of two years.
- D. The President of The University of Texas at Austin shall appoint one of the professional newspapermen for an initial term of one year, and shall appoint the other professional newspaperman for an initial term of two years.

7.

Should any voting member or members of the Board of Operating Trustees resign, become ineligible or for any other reason fail to serve, if such member be one who was appointed by the President of The University of Texas at Austin, such President, after consultation with the Operating Trustees, shall appoint a successor, and if ~~such member be one who is otherwise selected, then a majority of the Operating Trustees, shall appoint a successor,~~ *Joseph* and if such member be one who is otherwise selected, then a majority of the Operating Trustees, after consultation with the President, shall appoint a successor trustee, and in the event of a tie vote by the Operating Trustees, the President shall make such appointment. Each successor trustee shall possess the qualifications of his predecessor in office.

8.

In addition to the aforementioned voting members of the Board of Operating Trustees, the following persons shall serve as ex officio, non-voting members: The Dean of Students or his representative; the Editorial Manager of The Daily Texan; the General Manager of the publications; the Editor and Managing Editor of The Daily Texan; and the student editors of all other publications published by the Operating Trustees.

9.

Until the selection of the initial eleven-member Board of Operating Trustees as set out under Paragraph 5 hereof, there shall be nine (9) Operating Trustees as follows:

<u>Name</u>	<u>Address</u>
Mr. Bob Binder	Students Association Union Bldg. 323 The University of Texas at Austin Austin, Texas 78712
Dr. Norris Davis	3303 River Road Austin, Texas 78703
Dr. Charles Bonjean	Route 8, Box 428 Austin, Texas 78703
Dr. Eugene Sauls	5801 Westslope Austin, Texas 78731
Dr. Frank Pierce	4202 Venabo Austin, Texas 78731
Mr. David Stok	2208 Nueces Austin, Texas 78705
Mr. David Mincberg	2600 Rio Grande Austin, Texas 78705
Mr. Tim Donahue	3509 Cherry Lane Austin, Texas 78703
Mr. John Fox	401 West 38th Austin, Texas 78705

10.

The officers of the Board of Operating Trustees shall be a President, a Vice-President and a Secretary, and such other officers as the Board of Operating Trustees may from time to time find necessary to carry on the business of the publications. Officers shall be elected from among the voting members of the Board of Operating Trustees at the first meeting after June 1 of each year. Officers' terms shall be for one year, but a person is eligible to serve an additional one-year term.

11. *JL.*

At least three weeks prior to the spring student government elections, there shall be a student publications election on the campus of The University of Texas at Austin. At such election there shall be elected the Editor of The Daily Texan by the students of The University of Texas at Austin, but voting members of the Board of Operating Trustees shall appoint the Editor of The Daily Texan in the case of a vacancy. The eligibility of a candidate for Editor of The Daily Texan must be certified to by the Operating Trustees on standards set out in their Handbook prior to the time of said election. The Operating Trustees shall set out in its Handbook the conditions under which said elections may be held, including length of the campaign. The Editor of The Daily Texan shall serve for a term of one year beginning on June 1. There shall also be elected at this election the two student members of the Board of Operating Trustees (one student to be elected each year after the first spring election) as provided in Section 5 B.

12.

Subject to the provisions of this instrument, in the performance of all of its duties and in the exercise of all of its powers, the Board of Operating Trustees shall be subject to the direction of the Regents' Rules and Regulations. The Board of Operating Trustees shall conduct its meetings in strict adherence to Roberts' Rules of Order.

13.

There shall be an Executive Committee of the Board of Operating Trustees to be composed of three faculty members and two journalism students to be elected by the Board of Operating Trustees from its membership.

14.

The Executive Committee shall appoint a General Manager who shall be selected annually during the month of May for the fiscal year beginning September 1. The Executive Committee shall determine the compensation of the General Manager. The duties of the General Manager shall be prescribed by the Executive Committee, subject to the basic policies set forth by the Operating Trustees. The Editorial Manager(s) will be appointed by the Executive Committee, subject to basic policies set forth by the Operating Trustees. The Executive Committee shall determine the compensation of the Editorial Manager(s). The Editorial Manager of The Daily Texan shall be authorized to coordinate the activities between The Daily Texan and the Department of Journalism so as to secure the most effective use of the journalism laboratories and classes in the preparation of material for The Daily Texan. The Executive Committee shall fix the compensation of all editorial workers on student publications, subject to the final approval of the Operating Trustees. The Executive Committee shall appoint and fill all vacancies for Editor and Managing Editor of every publication, except The Daily Texan, and shall fix their compensation subject to final approval of the Operating Trustees at their next regular meeting.

15.

The Executive Committee is authorized to implement and is responsible for implementation of the policies of the Operating Trustees between meetings of the Operating Trustees.

16.

A definitive relationship between the Department of Journalism of The University of Texas at Austin and The Daily Texan published by the Operating Trustees must exist. Accordingly, the President of The University of Texas at Austin shall promulgate an operating procedure to establish this relationship. The operating procedure may be amended from time to time by mutual agreement between the Department of Journalism, through its chairman, and the Operating Trustees, with the concurrence of the President of The University of Texas at Austin. In the event the Chairman of the Department and the Board of Operating Trustees are unable to agree on amendments, the President of The University of Texas at Austin shall make the final decision.

17.

There shall be established within the Board of Operating Trustees a Review Committee which shall be composed of one member of the journalism faculty, one journalism student, and one professional newspaperman. Such members are to be elected by the Operating Trustees out of the membership of the Board of Operating Trustees. All appeals on material withheld from publication by the Editorial Manager, or respective publications supervisors, shall be considered by the Review Committee within 24 hours of the action. A decision of the Review Committee may be appealed to the Operating Trustees, but seven affirmative votes of the Operating Trustees are required to overrule said decision of the Review Committee. In all such matters, the actions of the Operating Trustees shall be final and complete without review outside the Operating Trustees.

18.

It shall be the duty of the Board of Operating Trustees to furnish on request to the President of The University of Texas at Austin, the Chancellor of The University of Texas System and the Board of Regents of The University of Texas System, within two weeks of such request, any special reports requested by such officials.

19.

At least eighteen copies of the minutes of all meetings of the Operating Trustees shall be delivered promptly to the President of The University of Texas at Austin for distribution to the Chancellor, the Vice-Chancellor for Academic Affairs, the members of the Board of Regents, the Secretary to the Board of Regents and such members of The University of Texas at Austin administration as the President of The University of Texas at Austin may direct. No action of the Operating Trustees shall have any force or effect unless included in the minutes and until it has been approved by the President of The University of Texas at Austin, except actions of the Operating Trustees pertaining to decisions of the Review Committee,

and except as to actions of the Operating Trustees with respect to the appointment, discipline or removal of editors, which actions need only be reported in the minutes for information, but are not reviewable outside the Board of Operating Trustees.

20.

No budget or budget amendment adopted by the Operating Trustees shall have any force or effect until such budget or budget amendment has been approved by the Board of Regents.

21.

No expenditure shall be made by the Operating Trustees unless it is made in accordance with and pursuant to a budget item that has been previously adopted by the Operating Trustees and approved by the Board of Regents.

22.

Within ninety days following the close of each fiscal year, the President of The University of Texas at Austin shall be furnished for distribution to the Chancellor and to the members of the Board of Regents, the Secretary to the Board of Regents and to such members of The University of Texas at Austin administration as the President of The University of Texas at Austin may direct, at least fifteen copies of a complete audit of the fiscal year.

23.

All employees, editors, editorial workers and staff members employed to work on student publications under the control and jurisdiction of the Operating Trustees including all employees of the corporation known as Texas Student Publications, Inc. holding office or employment as of the effective date of this Declaration of Trust shall continue in office or employment (unless changed by the Operating Trustees in accordance with the Declaration of Trust).

24.

Subject to Section 23 of this Declaration of Trust, the Operating Trustees shall have the authority: (1) to appoint the Managing Editor of The Daily Texan from among qualified students; (2) to take disciplinary action against the employees, editors, editorial workers and staff members of student publications, including the removal from office after due notice, for a violation of the policies of the Operating Trustees or for nonperformance of duties; such removal shall require a majority vote (action of the Operating Trustees in the matter of the appointment, discipline and removal of editors shall be final and complete); provided, however, that no action taken by the Operating Trustees with respect to the employment, dismissal, salary or duties and responsibilities of either the General Manager or the Editorial Manager(s) shall have any force or effect until it has been approved by the Board of Regents; and (3) to determine the character and policies of all student publications.

25.

Since all funds utilized in the operations of student publications are under the direct control of an agency of the University, the Operating Trustees, the Vice-President for Business Affairs of The University of Texas at Austin and the Director of The University of Texas at Austin Personnel Office shall immediately make arrangements for assuring that all appropriate personnel are placed under the budgetary and personnel regulations applicable to other University of Texas at Austin employees.

26.

The Operating Trustees shall promulgate and implement a handbook which shall contain the operating policies of the Operating Trustees.

27.

The provisions of this instrument may be amended only with the concurrence of Trustees and a majority of the Operating Trustees.



28.

Trustees, by the execution of this instrument, accept the assets hereby conveyed and delivered, subject to all of the terms and provisions of this instrument.

TEXAS STUDENT PUBLICATIONS, INC.

ATTEST:

David Minberg  
David Minberg, Secretary

By: Bob Binder  
Bob Binder, Chairman

DIRECTORS

1. [Signature]
2. [Signature]
3. [Signature]
4. Morris G. Davis
5. [Signature]
6. [Signature]
7. [Signature]
8. Frank N. Pierce

THE BOARD OF REGENTS OF THE UNIVERSITY  
OF TEXAS SYSTEM

ATTEST:

Betty Anne Thedford  
Betty Anne Thedford, Secretary

By: [Signature]  
John Peace, Chairman



OFFICE OF THE SECRETARY OF STATE

CERTIFICATE OF DISSOLUTION  
OF

TEXAS STUDENT PUBLICATIONS, INC.

The undersigned, as Secretary of State of the State of Texas, hereby certifies that duplicate originals of Articles of Dissolution of the above Corporation, duly signed and verified pursuant to the provisions of the Texas Non-Profit Corporation Act, have been received in this office and are found to conform to law.

ACCORDINGLY the undersigned, as such Secretary of State, and by virtue of the authority vested in him by law, hereby issues this Certificate of Dissolution and attaches hereto a duplicate original of the Articles of Dissolution.

Dated October 1, 1971.

Secretary of State

ARTICLES OF DISSOLUTION  
of  
TEXAS STUDENT PUBLICATIONS, INC.

Filed in the Office of the  
Secretary of State of Texas  
This 1st day of Oct 1971  
S. W. Neff  
Director, Corporation Division

Pursuant to the provisions of Article 6.05 of the Texas Non-Profit Corporation Act, the undersigned corporation adopts the following Articles of Dissolution for the purpose of dissolving the corporation:

- 1. The name of the corporation is Texas Student Publications, Inc.
- 2. A resolution to dissolve was adopted in the following manner:

"The resolution to dissolve was adopted at a meeting of the board of directors held on August 27, 1971, and received the vote of a majority of the directors in office, there being no members having voting rights in respect thereof."

3. All debts, obligations and liabilities of the corporation have been paid and discharged or adequate provision has been made therefor.

4. All remaining property and assets of the corporation have been transferred, conveyed or distributed in accordance with the provisions of the Texas Non-Profit Corporation Act.

5. There are no suits pending against the corporation in any court.

Dated the 1st day of October, A.D. 1971.

TEXAS STUDENT PUBLICATIONS, INC.

WITNESS

David M. Minberg  
David Minberg, Secretary

By: Bob Binder  
Bob Binder, Chairman of the Board of Directors, there being no President

The State of Texas, )  
County of Travis. )

I, Joseph Lutting, a Notary Public, do hereby certify that on this day personally appeared before me Bob Binder, who, being duly sworn, declared that he is Chairman of the Board of Directors of the corporation executing the foregoing document, that he signed the foregoing document in the capacity therein set forth, and that the statements therein contained are true.

In Witness Whereof, I have hereunto set my hand and seal this 1st day of October, A. D. 1971.

Joseph Lutting  
Notary Public in and for  
Travis County, Texas

NO. 190,540

THE BOARD OF REGENTS OF	(	
THE UNIVERSITY OF TEXAS	)	
SYSTEM AND STATE OF TEXAS	(	
ON THE RELATION OF THE BOARD	)	
OF REGENTS OF THE UNIVERSITY	(	IN THE DISTRICT COURT OF
OF TEXAS SYSTEM,	)	
	(	
Plaintiffs	)	
	(	
V.	)	TRAVIS COUNTY, TEXAS
	(	
TEXAS STUDENT PUBLICATIONS,	)	
INC., BOB BINDER, NORRIS G.	(	
DAVIS, EUGENE H. SAULS,	)	167TH JUDICIAL DISTRICT
FRANK N. PIERCE, DAVID M.	(	
MINCBERG, CHARLES M. BONJEAN,	)	
TIMOTHY A DONAHUE, JOHN H.	(	
FOX AND DAVID STOK,	)	
	(	
Defendants	)	

MOTION FOR LEAVE TO TAKE NON-SUIT

TO THE HONORABLE JUDGE OF SAID COURT:

NOW RESPECTFULLY COME Plaintiffs and Defendants and Cross-Plaintiffs, and each and all of them, and show the Court that all matters in controversy in this cause have been resolved and that all parties hereto respectfully pray that all claims asserted by them be dismissed with prejudice.

CRAWFORD C. MARTIN  
Attorney General of Texas

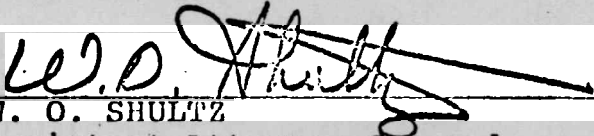
  
W. O. SHULTZ  
Assistant Attorney General

P. O. Box 12548  
Capitol Station  
Austin, Texas 78711

MILLS, SHIRLEY, McMICKEN & ECKEL  
PRESTON SHIRLEY

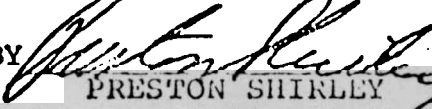
BY   
PRESTON SHIRLEY  
600 U. S. National Bank Bldg.  
Galveston, Texas 77550

ATTORNEYS FOR PLAINTIFFS

FILED  
Oct 1 11 20 AM '51

GRAVES, DOUGHERTY, GEE,  
HEARON, MOODY & GARWOOD  
THOMAS G. GEE  
204 Austin National Bank Bldg.  
Austin, Texas 78701

JOSEPH LATTING

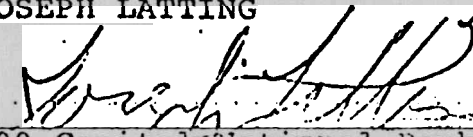
  
500 Capital National Bank Bldg.  
Austin, Texas 78701

ATTORNEYS FOR DEFENDANTS  
AND CROSS-PLAINTIFFS

ORDER

The above and foregoing joint motion is hereby granted as to all parties, and the causes of action alleged by all parties hereto are hereby dismissed with prejudice, with each party to pay the Court costs accrued by it.

RENDERED and ENTERED this 1st day of October, 1971.

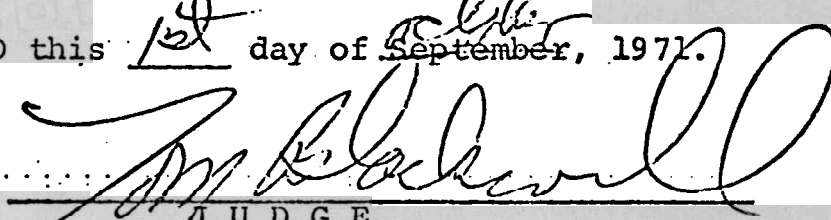
  
JUDGE

The Operating Procedure  
of  
The Daily Texan  
The Department of Journalism  
of  
The University of Texas at Austin

Section 1. General. (a) In promulgation of the Operating Procedure of The Daily Texan with The Department of Journalism of The University of Texas at Austin, the essential authority and responsibility delegated to student editors is restated at the outset: in all matters of news and editorial content, the student editors will exert final judgment in day-to-day operations except those matters on appeal. In all matters relating to appeals of editorial and news content of student publications, The University of Texas at Austin Board of Operating Trustees is the final arbiter.

(b) The Chairman of the Journalism Department shall assign faculty members to counsel and work with The Daily Texan staff members who have day-to-day responsibility for general news assignments, editing and makeup of the general portion of the Texan. The Chairman of the Journalism Department shall also make available faculty members to work with special departments of the Texan on request.

(c) The faculty members may not be censors. The faculty members shall be directed by the Chairman of the Journalism Department and authorized by the Board of Operating Trustees, however, to see that students working in journalism labs associated with The Daily Texan carry out the provisions of the Board of Operating Trustees Handbook to the letter.

(d) The faculty members shall function in a positive manner assisting student editors and collaborating with students in the development of story assignments from inception to final publication. As part of this function, the faculty members shall relate to student editors information designed to achieve the best possible techniques and results in the areas of reporting, photography, editing and makeup. Dialogue with competent faculty with previous professional experience is expected to prevent mistakes which could be embarrassing to the student editors.

(e) The Board of Operating Trustees shall direct its student staff and permanent staff to cooperate with the respective faculty members appointed by the Chairman of the Journalism Department.

Section 2. ASSIGNMENT SHEETS. To avoid duplication of interviews and reporting the Reporting Laboratory Supervisor of the Department of Journalism and the Texan Managing Editor, or his designated representative, in cooperation with each other, shall provide the assignment sheets for The Daily Texan.

Section 3. COPY FROM REPORTING LABORATORY. Any news copy turned over to the Texan staff from a student in the Reporting Laboratory may not be altered in meaning or changed substantially by the Texan staff without consulting with the Reporting Laboratory Supervisor or the student reporter except as the change relates to length.

Section 4. RIGHT TO HOLD COPY. As may be set out in the Board of Operating Trustees Handbook, the Editorial Manager may hold any copy that is deemed libelous or not in accord with the policies of the Board of Operating Trustees. In the case of material or copy produced as an academic assignment in a class, in the reporting laboratory or the editing laboratory, any faculty member assigned to work with the staff of The Daily Texan under the provisions of Section 1 of this Procedure or the Editorial Manager may hold such material or copy that is deemed by such faculty member or editorial manager to be libelous or not in accord with the policies of the Texan as set out in the Handbook of the Board of Operating Trustees. Immediately after this action, the person holding the copy shall report his exercise of that privilege to the Editor or Managing Editor of The Daily Texan. The Editor or the Managing Editor may submit the copy to the Review Committee established by the Declaration of Trust of the Board of Operating Trustees, and, if overruled by the Review Committee, to the Board of Operating Trustees for their decision, all under the provisions of said Operating Trustees' Declaration of Trust. Appeals may be made only at the request of the Editor or Managing Editor.

PROMULGATED by the President of The University of Texas at Austin on this 19th day of November, A.D. 1971.

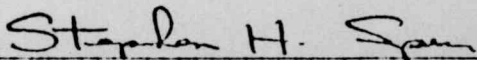
  
\_\_\_\_\_  
President, The University of Texas at Austin

4. U. T. Austin: Budgetary and Personnel Matters Relating to Post-Season Game. --This item is listed on the Agenda in the event any emergency recommendations are made with respect to a bowl game. If such is the case, the recommendations may be transferred either to the Academic and Developmental Affairs Committee or to the Committee of the Whole for consideration.

5. U. T. El Paso: Nominations to The University of Texas at El Paso Development Board. --

Chancellor LeMaistre concurs in the recommendations of President Smiley regarding nominations as set forth below to The University of Texas at El Paso Development Board, and requests the Board's approval of these nominations.

Initial Terms: September 1, 1971 through August 31, 1974

Dr. Eugenio A. Aguilar  
Mr. Charles H. Foster  
Mr. Dennis H. Lane  
Mr. Jose G. Santos  
Mr. Fred D. Schneider

Reappointments to Terms: September 1, 1971 through  
August 31, 1974

Mr. C. H. Leavell  
Mr. George G. Matkin  
Mr. Edward F. Schwartz

Following approval by the Board, and acceptance by the nominees, the full membership and terms of this Development Board will be reported for the record at a later meeting.



Office of the President

# The University of Texas at El Paso

October 11, 1971

CHANCELLOR'S OFFICE U. of T.

Acknowledged..... File.....

REC'D OCT 13 1971

Dr. Charles A. LeMaistre, Chancellor  
The University of Texas System  
P. O. Drawer 7969  
Austin, Texas 78712

To..... For Info and Return  
To..... Please Advise Me  
To..... Please Handle

Dear Dr. LeMaistre:

I write to nominate the following as new appointees to the Development Board for The University of Texas at El Paso:

- Dr. Eugenio A. Aguilar
- Mr. Charles H. Foster
- Mr. Dennis H. Lane
- Mr. Jose G. Santos
- Mr. Fred D. Schneider

The following, whose terms expired on August 31, are nominated for a second three-year term:

- Mr. C. H. Leavell
- Mr. George G. Matkin
- Mr. Edward F. Schwartz

I request that these names be submitted to the Board of Regents for confirmation at the first opportunity.

The following members of the Development Board have concluded their terms. I am sure that each of them would appreciate a letter from you and any other persons you think appropriate, thanking them for their services to The University of Texas at El Paso.

- Mr. H. D. Fulwiler
- Mr. Dorrance D. Roderick

Cordially yours,

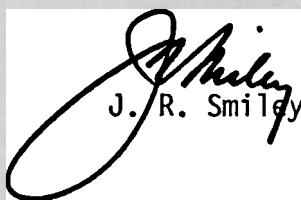

J. R. Smiley



6. U. T. Permian Basin: Legal Matters Relating Thereto. --Chairman Peace will report on the status of the lawsuit styled by H. Winston Hull, et al., v. Robert S. Calvert, Comptroller of Public Accounts (U. T. Permian Basin case) and his request to the Attorney General to employ Mr. Robert Brown, attorney of Houston, Harris County, Texas, as Special Assistant Attorney General to represent the University and to assist Mr. Malcolm Quick in oral argument before the Texas Supreme Court on November 3, 1971, and to authorize The University of Texas System to pay for Mr. Brown's services from state funds.

7. Galveston Medical Branch: Nomination of Dr. Donald Kennedy to the National Scientific Advisory Board of the Marine Biomedical Institute. --

At their meeting on December 10, 1970, the Board of Regents approved the nomination of Dr. H. K. Hartline to membership on the National Scientific Advisory Board of the Marine Biomedical Institute. On being contacted Dr. Hartline had to decline this nomination because of recent heavy commitments.

Chancellor LeMaistre concurs in the recommendation of President Blocker and Dr. Wolf that Dr. Donald Kennedy, an outstanding scientist and currently professor and chairman of the Department of Biological Sciences at Stanford University, be approved by the Board as a nominee to replace Dr. Hartline.

Following this approval, and the acceptance of Dr. Kennedy, the full membership of this Advisory Board will be reported for the record.

8. Galveston Medical Branch: Legal Matters Regarding Possible Sale of Bonds for Expansion of John Sealy Hospital and Other Facilities. --

Deputy Chancellor Walker requests permission to discuss the legal and other aspects related to the proposed expansion of John Sealy Hospital and other facilities related thereto, and specifically recommends:

1. That a committee, consisting of Regent Erwin, Deputy Chancellor Walker, Associate Deputy Chancellor Shelton and Assistant Deputy Chancellor Landrum be appointed to confer with the Trustees of the Sealy & Smith Foundation, and to employ and consult with Bond Counsel and a Bond Consultant, if necessary, in order to develop a feasible plan for the financing of the expansion of John Sealy Hospital.
2. That Sam Maclin and the firm of McCall, Parkhurst & Horton, be employed as Bond Consultant and Bond Counsel respectively, in the event the Committee deems it necessary to do so.

If these recommendations are approved, it is contemplated that a report will be made for the Board's consideration at the January 28, 1972, meeting.

9. Legal Aspects re Gifts (Dr. Ransom). --

COMMITTEE OF THE WHOLE  
EXECUTIVE SESSION

Emergency Items

Date: December 3, 1971

- |  | <u>Page</u> |
|--|-------------|
| 10. U. T. Austin: Discussion of Personnel and Fiscal Matters Related to the Webb Symposium                               | 15          |
| 11. M. D. Anderson: Legal Aspects Involved with Hercules, Inc.   | 17          |
| 12. U. T. Austin: Implementation of Waiver Provided in the Rules and Regulations, Part One, Chapter III, Subsection 16.4 | 17          |

13. Appro. 25 M ? Lighthouse Band

10. U. T. Austin: Discussion of Personnel and Fiscal Matters Related to the Webb Symposium. --

System Administration requests a discussion of this request from Provost Ross regarding the Webb Symposium, and endorsement of the proposed \$25,000 fund-raising effort by the Committee. System Administration will present a report of the status of this fund drive at the January meeting, and at that time will make a recommendation regarding a further appropriation.

Attached below are two letters which reflect the present status of planning and budgeting for this Symposium.



THE UNIVERSITY OF TEXAS AT AUSTIN  
OFFICE OF THE PRESIDENT  
AUSTIN, TEXAS 78712

*President*

November 18, 1971

Charles A. LeMaistre, M.D.  
Chancellor  
The University of Texas System

Dear Mickey:

I am transmitting herewith a letter from Provost Ross, requesting an allocation of up to \$25,000 provided that Dr. Frantz cannot raise the funds necessary to conduct the Webb Symposium at a budget of \$75,000. It is my understanding that the Regents wanted to deal directly with this particular project. Please advise me as to what further action I should take.

Sincerely yours,

A handwritten signature in cursive script, appearing to read "Spurr".

Stephen H. Spurr

SHS/gp  
Enclosure

cc: Dr. Stanley R. Ross



THE UNIVERSITY OF TEXAS AT AUSTIN  
OFFICE OF THE PROVOST  
ARTS AND SCIENCES  
AUSTIN, TEXAS 78712

PRESIDENT'S OFFICE  
U. T. AUSTIN  
REC'D NOV 12 1971  
REFER TO \_\_\_\_\_  
HANDLE \_\_\_\_\_  
COMMENT & RETURN \_\_\_\_\_  
FILE OR DISCARD \_\_\_\_\_

November 11, 1971

Dr. Stephen H. Spurr  
President  
Main Building 102

Dear Steve:

I am writing to you to suggest that you request from the Chancellor and from the Board of Regents supplementary financial assistance in the amount of \$25,000 to enable us to carry to a successful conclusion the Walter Prescott Webb Symposium scheduled to be held in Austin, April 3-5, 1972.

Originally the brainchild of a group of admirers of Professor Webb, the proposal subsequently enjoyed the public endorsement of the Arts & Sciences Foundation Council and of the Board of Regents. Last year, the new administration placed the planning of the Walter Prescott Webb Symposium under the control of a group consisting of UT at Austin faculty and staff members under the Chairmanship of Joe B. Frantz, Professor of History. Other members of the Committee are Professor Standish Meacham, Chairman of the History Department; Professor Robert A. Divine of the History Department; Professor F. Ray Marshall, Chairman of the Department of Economics, and Mr. Frank Wardlaw, Director of the University Press. In addition, I sat with the members of the Committee as often as my schedule permitted.

It was this Committee which presented the formalized plans for the Symposium through channels to the Board of Regents. The proposed program, based on \$50,000 allocated by the Arts & Sciences Foundation from funds in that amount donated for this purpose by Major J. R. Parten and Mr. C.B. Smith, was endorsed by the Academic and Developmental Affairs Committee of the Board of Regents and accepted by the entire Board. It was understood, however, that if additional funds are needed for this program, it would require prior approval of the Board of Regents.

More recently, it has become obvious, based on the responses from proposed participants, that additional funds would indeed be required. Accordingly, I am suggesting that you request an allocation in the amount of \$25,000 which together with the committed funds would represent the minimum amount necessary to carry this significant program to a successful conclusion.

As you will recall, it is proposed to have an international Symposium bringing leading scholars to the campus to suggest and identify the problems which the world will face at the beginning of the 21st Century. Younger thinkers would be invited to sit with the senior group as critics, challengers and discussers.

I am appending the proposed minimum, not optimum, budget and a list of the distinguished group from whom tentative acceptances have been received. Not only do I feel that we are committed to carry this undertaking through to conclusion and any failure to do so would be an embarrassment to all concerned, but I truly believe that we have the prospect of a significant gathering which will be cited for many, many years to come.

Sincerely yours,

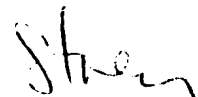
  
Stanley R. Ross  
Provost

SRR:gdg  
Enclosures

P.S. It is understood that Dr. Frantz and others would continue to endeavor to raise money from private sources.

BUDGET

(Total--\$75,000)

1.	<u>Honoraria</u>		
	18 Principals		* \$37,000
2.	<u>Travel</u>		
	a. <u>Foreign</u>		\$ 7,500
	(includes air fare from Russia, France, England, Hong Kong, Chile, Yugoslavia, and Ethiopia)		
	b. <u>Domestic</u>		
	1. Principals		\$ 3,000
	2. Commentators (14)		\$ 3,700
			* \$14,200
3.	<u>Accommodations in Austin</u>		
	a. Rooms at Dobie Center for 4 nights		\$ 1,300
	b. Conference rooms and dining room at Thompson Center		\$ 300
	c. Breakfasts		\$ 200
	d. Luncheons		\$ 350
	e. Opening dinner (for participants, U. T. Administrators and friends of the University)		\$ 1,500
	f. Faculty dinners ( 6 dinners @ \$50)		\$ 300
	g. Friday Mountain Ranch picnic ( 40 @ \$15)		\$ 600
	h. Final dinner ( 40 @ \$15)		\$ 600
			*\$ 5,150
4.	<u>Administrative</u>		
	a. Secretary		\$ 3,000
	b. Printing (programs)		\$ 2,000
	c. Recording and transcribing		\$ 500
	d. Office supplies (including \$1,500 for Xerox of papers)		\$ 2,150
	e. Larry Goodwyn (already paid)		\$11,000
			* \$18,650

Total Budget .....	\$75,000
Allocated funds .....	<u>\$50,000</u>
Funds Requested	\$25,000

INVITED PARTICIPANTS -- TENTATIVE ACCEPTANCE

RAYMOND ARON--French philosopher and journalist

DANIEL BELL--Sociologist, author of "The Radical Right" and a member of the President's Commission on Technology. Former Labor Editor, Fortune Magazine.

AARON COPLAND--Noted American composer.

LOREN EISELEY--Anthropologist and author of "The Immense Journey", "The Unexpected Universe." Concerned about the uses of technology in the space age.

EDUARDO FREI--Past President of Chile.

ROBERT K. A. GARDINER--Native of Ghana, member of United Nations Economic Commission on Africa. Stationed in Addis Ababa.

BENTLEY GLASS--Biologist, professor at State University of New York, Stony Brook. Nationally known educator and scientist.

IRVING HOWE--Author, historian, critic. Author of books on twentieth century American life and letters--Sherwood Anderson, Faulkner, etc.

IVAN ILLICH--Theologian, philosopher of education. Has proposed radical reorganization of America's educational system.

HERMAN KAHN--Physicist. Futurologist. Author of "The Year Two Thousand" Director of Hudson Institute.

ALFRED KAZIN--Literary critic. Author of "On Native Grounds, A Walker in the City." Member American Academy of Arts and Sciences.

SOL M. LINOWITZ--Lawyer. Former chairman, Xerox Corporation. Former Ambassador to the Organization of American States.

NATHANIEL OWINGS--Architect and city planner. Fellow of American Institute of Architects. Partner, Skidmore, Owings and Merrill.

BRANISLAV SOSKIC--Yugoslavian economist, Institute of Economic Research, Belgrade.

Also invited; awaiting replies

PATRICIA HARRIS--Lawyer, Former Dean of Howard University, Law School.

CHRISTOPHER HILL--Master of Balliol College, Oxford, student of revolutionary and radical movements.

Vladimir Trukhanovsky--Leading Russian historian and editor of Voprosi Istorii

PU SHOU CH-ANG--Harvard-trained economist, from People's Republic of China.

11. M. D. Anderson: Legal Aspects Involved with Hercules, Inc. --  
 Dr. Clark wishes to present the possibility of joint sponsorship with Hercules, Inc., in the technical and professional management of Fort Detrick, Maryland, as a new cancer research facility with Hercules to provide the management and financial operation.
12. U. T. Austin: Implementation of Waiver Provided in the Rules and Regulations, Part One, Chapter III, Subsection 16.4 Regarding the Extension of a Leave of Absence Without Pay. --

Chancellor LeMaistre concurs in the recommendation of President Spurr that the request of Secretary of Defense Melvin Laird be approved by the Board of Regents which would allow Assistant Professor Roger E. Shields a third year leave of absence to continue his responsibilities on the staff of Secretary Laird.

The request of Secretary Laird is detailed in the attached telegram and supported by the letters also attached from the Chairman of the Department of Finance at The University of Texas at Austin and President Spurr.

This item was not received in time to be submitted to the Secretary of State for publication; hence, it will be resubmitted at the January meeting for ratification.

		<h1>Telegram</h1>	
1029P CST NOV 30 71 NSA357		(Called in 9 am)	
NS SNB050 JR GOVT PD 12 EXTRA FP FT SAM HOUSTON TEX 30 917P		HANDLE _____ COMMENT & RETURN _____ FILE OR DISCARD _____	
CST DR STEPHEN H SPURR PRESIDENT MB102		471-1233 Adse. BY U 2908 A DLD	
(REPORT DELIVERY PERSONAL DELIVERY ONLY)			
UNIVERSITY OF TEXAS AUSTIN TEXAS 010051 4237			
DEAR DR. SPURR:			
I AM WRITING TO SUPPORT AN EXTENSION OF ONE YEAR IN THE CURRENT LEAVE OF ABSENCE OF DR. ROGER SHIELDS, NOW ON LEAVE FROM THE FINANCE DEPARTMENT OF THE UNIVERSITY OF TEXAS, UNTIL THE SPRING SEMESTER OF 1972. I SUPPORT THE EXTENSION OF LEAVE BECAUSE I STRONGLY BELIEVE THAT IT WOULD BE IN THE BEST INTERESTS OF OUR NATION FOR ROGER TO REMAIN IN HIS PRESENT SENSITIVE POSITION DURING THE CRITICAL YEAR AHEAD OF US, AS WE CONCLUDE OUR PROGRAM			



OF VIETNAMIZATION AND ENSURE THAT OUR MEN NOW HELD CAPTIVE ARE RETURNED SAFELY HOME.

DR. SHIELDS HAS IMPORTANT RESPONSIBILITIES IN MATTERS THAT COMMAND MY PERSONAL ATTENTION. FIRST OF ALL, HE IS CHARGED WITH OVER-SEEING MANY ECONOMIC ASPECTS OF THE VIETNAMIZATION PROGRAM, AND IN DISCHARGING HIS DUTIES HE REPRESENTS THE DEPARTMENT OF DEFENSE IN RELEVANT INTERAGENCY COUNCILS AT THE HIGHEST LEVEL. NOTHING IS MORE CRITICAL TO THE VIETNAMIZATION PROGRAM THAN THE ECONOMIC VIA-BILITY OF SOUTH VIETNAM, AND ROGER'S BACKGROUND AND EXPERIENCE MAKE HIM DIFFICULT TO REPLACE.

ROGER ALSO SERVES AS A PRINCIPAL DEFENSE DEPARTMENT REPRESENTATIVE TO THE PRESIDENT'S COUNCIL ON INTERNATIONAL ECONOMIC POLICY. SUCCESSFUL FUNCTIONING OF THIS COUNCIL IS ESSENTIAL IF THE SERIOUS PROBLEMS IN THE SPHERE OF INTERNATIONAL ECONOMIC RELATIONS ARE TO RESOLVED, AND CONTINUITY IN DEFENSE REPRESENTATION IS THEREFORE OF SPECIAL IMPORTANCE AT THIS TIME.

MOST IMPORTANT OF ALL, ROGER SERVES AS MY PRINCIPAL ASSISTANT FOR AFFAIRS RELATED TO PRISONERS OF WAR AND MISSING IN ACTION. WE ARE ENTERING A PERIOD THAT WILL BE CRITICAL AS FAR AS ULTIMATE SUCCESS IN ACHIEVING THE RELEASE OF OUR MEN HELD CAPTIVE IS CONCERNED. I DO NOT WISH TO SEE ANY ACTION TAKEN THAT MIGHT DELAY BY A SINGLE DAY THE RETURN OF THESE BRAVE MEN. THE LOSS OF ROGER SHIELDS AT THIS CRUCIAL TIME, WITH HIS SPECIAL EXPERIENCE AND KNOWLEDGE, WOULD IN MY OPINION CREATE A RISK OF DELAY.

I AM GRATIFIED THAT WE HAVE BEEN ABLE TO ATTRACT INTO GOVERNMENT MEN FROM THE ACADEMIC COMMUNITY WITH THE PROFESSIONAL AND PERSONAL QUALITIES OF ROGER SHIELDS. HE HAS CERTAINLY BEEN A CREDIT TO THE UNIVERSITY OF TEXAS AT AUSTIN. HIS PRESENT WORK, BESIDES BEING OF GREAT VALUE TO HIS COUNTRY, WILL SURELY MAKE HIM A MORE VALUABLE MEMBER OF YOUR FACULTY, NOT ONLY IN THE DEPARTMENT OF FINANCE BUT ALSO IN THE AREA OF PUBLIC AFFAIRS WHERE THE UNIVERSITY OF TEXAS HAS DEMONSTRATED SO MUCH INNOVATION AND LEADERSHIP.

BECAUSE OF THE SPECIAL CIRCUMSTANCES AT THE PRESENT TIME, I FEEL IT WOULD BE IN THE BEST INTERESTS OF BOTH THE DEPARTMENT OF DEFENSE AND THE UNIVERSITY OF TEXAS TO EXTEND ROGER SHIELDS, LEAVE OF ABSENCE. I SINCERELY HOPE THAT YOUR BOARD OF REGENTS MAY AGREE. SINCERELY,

SIGNED MELVIN R. LAIRD SECRETARY OF DEFENSE

THE SECRETARY OF DEFENSE THE PENTAGON, WASH., D.C.1 P 0100512  
DEC 71



THE UNIVERSITY OF TEXAS AT AUSTIN

AUSTIN, TEXAS 78712

Department of Finance

December 1, 1971

President Stephen H. Spurr  
University of Texas at Austin  
Main Building 102  
Austin, Texas

Re: Extension of the Leave of Absence  
for Roger E. Shields

Dear President Spurr:

The Budget Council of the Department of Finance unanimously recommends the extension for one year of Assistant Professor Roger E. Shields' current leave of absence, which expires in January, 1972. Professor Shields was originally granted a one-year leave of absence from The University of Texas at Austin in January, 1970, to pursue research in his specialty area of monetary economics with TEMPO, a California-based research organization. While there, he became integrally involved in projects for which the U.S. Department of Defense had contracted. Dr. Shields subsequently was invited to serve on the staff of Assistant Secretary of Defense G. Warren Nutter, in Washington, D.C., as a special assistant. Because of the nature of his activities, which appear to be critically important to the national defense, we recommended that his leave be extended for a second year (i.e., until January, 1972). It now appears that consummation of those functions, including an important role in conceiving a new prisoner-of-war exchange program, requires that Professor Shields remain in Washington, D.C. until January, 1973.

Professor Shields is a very highly regarded member of the faculty of the Department of Finance. He is one of our most promising younger faculty members--one whom we expect to attain national recognition academically in a fairly short period and one whom we strongly desire at this time to retain. Please use every means possible to secure the approval of the Board of Regents for this extension of academic leave.

Thank you very much for your attention to this matter and for your consideration.

Sincerely yours,

Lawrence L. Crum  
Chairman

Approved:

Burnard H. Sord, Associate Dean  
for Dean George Kozmetsky



THE UNIVERSITY OF TEXAS AT AUSTIN  
OFFICE OF THE PRESIDENT  
AUSTIN, TEXAS 78712

*President*

December 1, 1971

Charles A. LeMaistre, M.D.  
Chancellor  
The University of Texas System

Dear Dr. LeMaistre:

Assistant Professor Roger E. Shields of our Department of Finance will complete the second year of a two year leave of absence in January 1972. He is currently serving as an Assistant to Secretary of Defense Melvin R. Laird. Because of the nature of Professor Shields' duties, the Secretary has requested that we approve an extension of his leave of absence for another year. The Chairman of Professor Shields' Department and the Budget Council have unanimously recommended this extension. The extension of a leave of absence for a third year is contrary to our policy, but in view of the issue of national interest raised by Secretary Laird, I am recommending approval. I am attaching copies of a telegram from Secretary of Defense Laird and a letter from the Chairman of Professor Shields' Department.

Yours very truly,

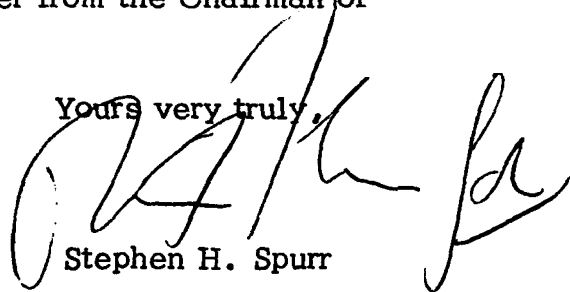

Stephen H. Spurr

SHS:jp  
Attachments

Recommend approval 12/11/71  
Charles LeMaistre

**BE IT RESOLVED BY THE BOARD OF REGENTS OF THE UNIVERSITY OF TEXAS SYSTEM** that with respect to the recent recommendations made by the Special NCAA Committee on Financial Aids, the official positions of the Board of Regents, The University of Texas at Austin, The University of Texas at Arlington and The University of Texas at El Paso are as follows:

1. We oppose a program of financial aid based on "need," because of the difficulty in the administration and enforcement of such a program. The definition of "hardship" cases, changes in family income, the identification of "emergency" situations, and loans to parents are only examples of administrative difficulties that would make equal enforcement almost impossible.
2. We oppose the numerical scholarship limitations that are proposed for football, basketball, baseball, and track. For example, the limitation on football scholarships should not be less than 45 new awards for a school participating in the university division.
3. We favor the establishment of a national candidate's declaration date for each sport in which an institution offers financial aid to prospective student athletes.
4. We favor the limiting of financial aid awards to one year, but we oppose the establishment of new or special "hearing" procedures for the student athlete who feels his award was not renewed for just cause, because there already exists an adequate opportunity for any student to appeal from any administrative decision by which he feels that he has been unfairly treated.
5. We oppose any limitation on the number of full-time and part-time coaches that may be employed. The employment of coaches should be an institutional decision; it is relatively unimportant from a budgetary standpoint; and any limitation would be extremely difficult to police effectively.
6. Finally, we feel that it is improper for all NCAA member schools, almost a third of whom do not field intercollegiate football teams, to have an equal voice and vote in determining rules and procedures which may unreasonably restrict a relatively small group of members in the conduct of their major football programs. The vote on matters affecting a particular sport or sports should be limited to those institutions that engage in intercollegiate competition in such sport or sports.

Cal

EMERGENCY ITEM

COMMITTEE OF THE WHOLE - EXECUTIVE SESSION

Date: December 3, 1971

Time: Following the Meeting of the Committee of the Whole - Open Session

Place: Academic Room, U.T. Austin

✓ S

U.T. Austin: Approval of Personnel and Expense Budgets Related to the Cotton Bowl Game on January 1, 1972.

Chancellor LeMaistre concurs in the recommendation of President Spurr and the Athletics Council of The University of Texas at Austin that the attached estimated budget and extra compensation to the athletics staff be approved for the Cotton Bowl Game on January 1, 1972. Attached are documents detailing the nature of this budget and appropriate administrative approvals.

Since this matter was not received in time to meet the public notice requirements, it is further requested that this item be resubmitted to the Board for ratification at the January meeting.



THE UNIVERSITY OF TEXAS AT AUSTIN  
OFFICE OF THE PRESIDENT  
AUSTIN, TEXAS 78712

December 1, 1971

Charles A. LeMaistre, M. D.  
Chancellor  
The University of Texas System

Dear Mickey:

Attached are copies of both an Estimated Budget and proposed Extra Compensation to the Athletics staff, which have been approved and recommended by the Athletics Council for the January 1, 1972 Cotton Bowl Game.

Mr. Colvin and I have reviewed the proposed budget and it is consistent with the approved budget for the last Cotton Bowl Game. The total estimated expenditures are \$5,500 more - primarily in estimated cost of travel expenses for team and staff and in increased compensation for the Athletics staff because of higher base salary rates.

I concur in the recommendations as presented and request that this be presented to the Regents for approval - hopefully, at the December 3 meeting.

Sincerely yours,

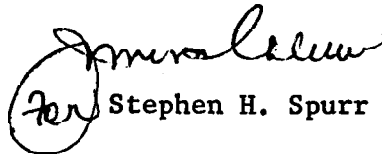
  
for Stephen H. Spurr

SHS:JHC:ms



THE UNIVERSITY OF TEXAS AT AUSTIN  
DEPARTMENT OF INTERCOLLEGIATE ATHLETICS  
AUSTIN, TEXAS 78712

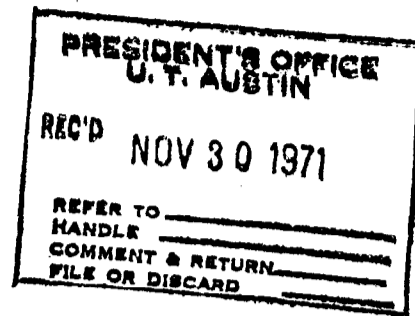

November 29, 1971

Dr. Stephen Spurr, President  
The University of Texas at Austin

Dear Dr. Spurr:

At its meeting on November 29, 1971, the Athletics Council developed and by formal action approved for recommendation to the Administration the attached budget for the 1972 Cotton Bowl Game.

In addition, I am attaching the letter providing for the approval of extra compensation in accordance with the Regental policy adopted several years ago.

Should you desire any detailed information concerning the various items in the budget, I shall be very happy to furnish it to you.

Sincerely yours

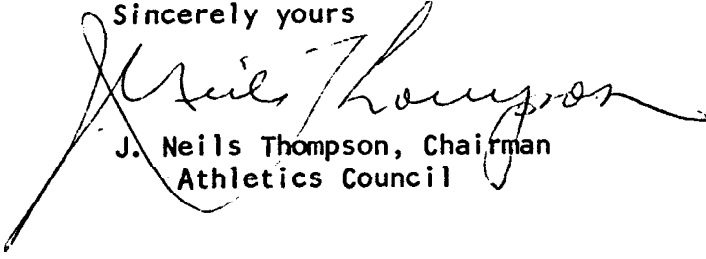
  
J. Neils Thompson, Chairman  
Athletics Council

Enclosure

ESTIMATED BUDGET FOR COTTON BOWL GAME  
January 1, 1972, Dallas

Estimated Income

\$130,000

Estimated Expenditures

Team & Athletics Staff - Travel, Accommodations, & Meals	\$34,000
Administration - Accommodations and Meals	500
Band - Travel, Accommodations, & Meals	10,500
Yell Leaders	500
Extra Compensation for Athletics Group	22,500
Awards	8,000
Complimentary Tickets	6,000
Public Relations - Sports News	500
Motion Picutre - Photography	1,000
Miscellaneous	<u>1,000</u>

*Total Estimated Expenditures*

84,500





THE UNIVERSITY OF TEXAS AT AUSTIN  
DEPARTMENT OF INTERCOLLEGIATE ATHLETICS  
AUSTIN, TEXAS 78712

PRESIDENT'S OFFICE  
U. T. AUSTIN  
REC'D NOV 30 1971  
REFER TO \_\_\_\_\_  
HANDLE \_\_\_\_\_  
COMMENT & RETURN \_\_\_\_\_  
FILE OR DISCARD \_\_\_\_\_

November 29, 1971

Dr. Stephen Spurr, President  
The University of Texas at Austin

Dear Dr. Spurr:

This is to request approval of the extra compensation to the Athletics Staff referred to in the estimated budget for the Cotton Bowl Game. The following is a list of the staff and the amount of compensation for each in accordance with the policy established by the Board of Regents in 1958 and modified in 1962:

Darrell K. Royal, Head Football Coach	\$35,000	8%	\$2,800.00
Fred S. Akers, Assistant Football Coach	18,000	8	1,440.00
William M. Campbell, Assistant Football Coach	23,500	8	1,880.00
Billy M. Ellington, Assistant Football Coach	19,000	8	1,520.00
Timothy M. Doerr, Assistant Football Coach	10,500	8	840.00
Emory Bellard, Assistant Football Coach	18,500	8	1,480.00
Willie L. Manley, Assistant Football Coach	16,500	8	1,320.00
David L. McWilliams, Assistant Football Coach	12,500	8	1,000.00
R. M. Patterson, Assistant Football Coach	18,000	8	1,440.00
Willie Zapalac, Assistant Football Coach	19,000	8	1,520.00
James C. Helms, Assistant Football Coach	10,000	8	800.00
Glen Swenson, Assistant Football Coach	12,500	8	1,000.00
Frank Medina, Trainer	11,500	5	575.00
James V. Blaylock, Procurement Officer	7,104	5	355.20
Joe Reneau, Team Physician	9,375	5	468.75
Albert H. Lundstedt, Business Manager of Athletics	15,000	5	750.00
Alfred R. Röchs, Asso. Business Manager of Athletics	12,600	5	630.00
Richard D. Boldt, Football Ticket Manager	8,160	5	408.00
Jones W. Ramsey, Sports News Director	12,500	5	625.00
William L. Little, Assistant Sports News Director	9,240	5	462.00
Ruth E. Gold, Executive Assistant	12,600	5	630.00
Michael Stephens, Assistant Trainer	7,440	5	372.00
			<u>\$22,315.95</u>

Sincerely yours

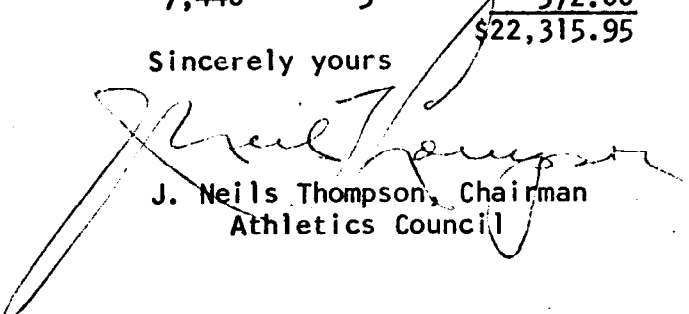
  
J. Neils Thompson, Chairman  
Athletics Council